



International Network
for Bamboo and Rattan

BAMBOO SCHOOL BUILDING



TRANSFER OF TECHNOLOGY MODEL (TOTEM)

Based on the Experiences and Lessons learned
from INBAR's Bamboo School Project, Ghana

Prepared by

Shyam K Paudel - Associate Expert, INBAR, China
Solomon Ayeh, Engineer, BRRI, Ghana

Technical Assistance

Building and Road Research Institute (BRRI), Kumasi, Ghana
TRADA International, UK

Drawings by

Christian Borchard - Architect, Berlin, Germany

Table of Contents

1.	Introduction	3
1.1	School Building in Kumasi Ghana	3
1.2	About the Manual	4
2.	Bamboo	4
2.1	Species	4
2.2	Age	4
2.3	Harvesting consideration	5
2.4	Other considerations	5
2.5	Quantity of Bamboo	6
3.	Preservation	6
3.1	Non chemical Method	6
3.2	Chemical Method	7
4.	Construction	10
4.1	Building Plan	11
4.2	Sub structure (Foundation)	12
4.2.1	Foundation layout	12
4.2.2	Foundation excavation	13
4.2.3	Leveling	13
4.2.4	Foundation wall	14
4.2.5	Foundation base for bamboo columns	15
4.2.6	Back filling	16
4.3	Wall fabrication (Prefabrication stage)	16
4.3.1	Drilling	16
4.3.2	Hardwood plugs	16
4.4	Wall structure	17
4.4.1	Erection of bamboo columns	17
4.4.2	Damp proofing	18
4.4.3	Wall plate	18
4.4.4	Construction of wall panels	19
4.4.5	Doors and windows	21
4.5	Roof	22
4.5.1	Roof Trusses	22
4.5.2	Assembling a truss	23
4.5.3	Trusses anchorage	24
4.5.4	Purlins	25
4.5.5	Roof covering	26
4.6	Finishing	26
5.	Drawings	27
5.1	Front elevation	27
5.2	Rear elevation	28
5.3	Side elevations	29
5.4	Plan 1/100	30
5.5	Plan 1/75 axis A-M	31
5.6	Plan 1/75 axis M-V	32
5.7	Section B 1/100	33
5.8	Section A 1/50	34
5.9	Details A,B,C	35
5.10	Details D,E,F	36
5.11	Foundation plan	37
	Reading materials	38

1. Introduction

The global shortage of housing materials especially in developing countries warrants serious consideration (Quintans 2000). It is estimated that at least 600 million dwellers in Africa, Asia and Latin America live in “life to health threatening homes”. Increasing populations in the developing world resulting in increased numbers of poor people coupled with decreasing timber resources, have compelled thinking about cheap and sustainable building materials.

It is not only dwellings that are in short supply in developing countries, but also public infrastructure such as schools and hospitals. States often have limited ability to afford such structures in every village causing many people deprived of basic needs of education and health. Any kind of easy and affordable option would be a viable alternative in the short run.

Bamboo has been used for the building construction for a long time. Throughout the world it is estimated that more than a billion people live in bamboo houses. Bamboo buildings are cheap, easy to construct and durable provided they are treated and used properly. Bamboo has proved to be a sustainable resource, which can be regenerated and multiplied easily with menial technology. Due to its versatile nature it is well known as an excellent material for construction purposes. It grows in most climates in tropical and subtropical regions where demands for cheap and affordable shelters are high.

1.1 School Building in Kumasi Ghana

Ghana is one of the developing African countries where the need of low cost housing is immense. The housing problem is acute since the backlog is already 420,000, which is increasing with the short supply of annual demands of 120,000 houses.

The problem is not only for the dwellings but also goes beyond. There are limited numbers of public infrastructures such as school and health centres in the rural areas. Only 76% children get primary school enrolment and 37% to secondary school. Many children in rural villages are deprived of primary education simply due to lack of school in the village and people lacks mean to send their children to the nearest school which is located far away from the village.



Picture 1: School children – future hope

Such circumstances demand for a cheap, quick and sustainable option to alleviate the problems. Bamboo, due to its great versatile characteristics, has a great potential for the mitigation.

From the lessons learning and experiences from other countries on bamboo housing, INBAR as a part of its mission has initiated to transfer technology on bamboo housing in Ghana. The first phase included mainly two activities: 1) building of demonstration bamboo school building and 2) bamboo housing workshop.

INBAR with the technical assistance from Building and Road Research Institute (BRRI), Kumasi and TRADA International built an exemplary bamboo school in Kumasi, Ghana. British High Commission Accra supported the programme financially for the programme.

1.2 About the manual

This manual is based on the school building that was built in Kumasi Ghana. Some of the construction systems have been adopted from Indian Plywood Industries Research and Training Institute (IPIRTI) in this building.

The manual may be useful for both technical and non- technical persons who are familiar with the building construction. Although the manual is basically relied upon school construction in Ghana, you can modify or adjust the system according to the local situations.

2. Bamboo

2.1 Species

Although very few numbers of bamboo species have been tested so far for their mechanical and physical properties, many species could be useful for the construction purpose. *Dendrocalamus strictus*, *Bambusa nutans*, *Bambusa vulgaris*, *Guadua aungustifoila*, *Phyllostachys pubescens* have commonly been used for the building construction by various bamboo building projects.

Beside aforementioned species, other species having required dimensions (height, diameter and culm thickness) with sound appearance could be useful for the construction purpose (details in the following sections). Local experiences and knowledge on application and durability of particular species of bamboo are highly useful in deciding the species.

2.2 Age

Generally 3 to 6 years old bamboo, which has not bloomed yet, is suitable for the construction purpose. The age determination of sympodial bamboo in natural stand is not easy. However, there are few general rules that might help to estimate the age of bamboo.

- ◆ For sympodial bamboo, outermost bamboos are generally younger one (in natural stand). So inner the position of the culm, the older it is.
- ◆ If the color of the trunk changes from clear and shiny green to gray greenish, and if the traditional white bands of each knot have almost disappeared and are replaced by hardly perceptible gray bands, then the bamboo shows clearly evidence of its maturity (Moran, 2003).
- ◆ Older bamboo turns its color into yellow.
- ◆ When you struck a bamboo with a tool, the sound of older bamboo is louder than that of younger one.
- ◆ Use your judgement from experiences.

2.3 Harvesting considerations

Time and methods of harvesting are important factors to prolong the life of bamboo. The right bamboo harvested in the right time or season would increase the chance of longevity. One should carefully consider these aspects during the harvesting.

2.3.1 Time of harvesting

- ◆ Harvest during the dry season. This is the time when culm has low moisture content and lessen the chance of attack by fungi.
- ◆ Don't harvest during the rainy season. Winter is the most preferred time for the harvesting.

2.3.2 Methods

- ◆ Cut the culms 20 to 30 cm above the ground or after the first node.
- ◆ After cutting, leave it in the same position for about 2 to 3 weeks with the support of tree, stone, nearby bamboo etc. This facilitates to draw out the starch content of bamboo.
- ◆ Use sharp tool for harvesting to avoid the skin damage.

2.3.3 Transportation

- ◆ Cut the bamboo into the pieces of at least 4-meter in length to make it easier for the transportation. However, the length of the pieces may vary according to the requirements
- ◆ Make bundles of ten pieces
- ◆ Tie them using rope or bamboo lath.
- ◆ Use head-loading if the destination is nearby. Use cart or truck for long distance transport.

2.3.4 Drying

Once bamboo arrives in the construction site

- ◆ Clean the ground where the culms would be stored
- ◆ If possible, spray the ground with lime water or other pesticides
- ◆ Overhead shade is recommended to protect the culms from rain and other atmospheric moistures
- ◆ Keep the bamboo for 2-3 weeks in standing position with the support of trees or other supports.

2.4 Other Considerations

2.4.1 Morphology

- ◆ Use bamboo without fissures, cracks or cuts on the surface.
- ◆ Use bamboo without signs of rotting, being attacked by insects or by fungi.
- ◆ Straight and less tapered bamboos are preferred. Only 2/3 of total natural length is useful for the construction. The rests could be used for strips or for other purposes.

2.4.2 Sizes of Bamboo

- ◆ For columns and trusses, the diameter of the bamboo should be at least 100 mm with at least 10-mm wall thickness. The thicker the wall, the higher the compression strength it possesses.
- ◆ For strips, wall thickness of 10mm or less is fine.

2.5 Quantity of Bamboo

The quantity of culms required depends upon the size of the building and the application of the bamboo. In Ghana a total of 300 culms of 4200 mm were required to build a 196 square meter of bamboo building with hardwood used for the purlins. An average of 1.5 culms of 4200mm length is required for a square meter of house.

Bamboo	Purpose	Size	Number	Remarks
Straight pole with culm thickness more than 12mm	Columns	3750, 3600, 3450, 3300 mm (Length)	70 poles	The varying column lengths were to suit the terraced design of the floor since the site sloped gently
Straight pole with culm thickness more than 10mm	Trusses	4200 mm (length)	70 poles	
Long strips	Wall: for vertical grids	15 mm width and 3300 mm long		Poles were splitted into strips.
Short strips	Wall: for horizontal grids	15 mm width and 1100 mm long		

3. Preservation of Bamboo

The service period life of bamboo is governed by its exposure and durability. In general it has been found that untreated bamboo has an average life of 1-3 years where it is directly exposed to soil and atmosphere. When used under cover, the life expectancy of bamboo increases to 4 to 7 years but can be as high as 10-15 years in highly favorable circumstances (Jenssen, 1988; Jayanetti and Follet, 1998).

Preservation is most important to prolong the durability of services. Two methods are generally used.

3.1 Non Chemical Method

A. Reducing starch content

Starch makes bamboo vulnerable to be attacked by fungi and termites. Therefore, reducing starch content of bamboo is the best way to make it less vulnerable. You can reduce starch content by:

- ◆ Keeping the culm in a vertical position under a shade for a week after harvesting.
- ◆ Harvesting only the mature bamboos.
- ◆ Harvesting in winter season
- ◆ By soaking the bamboo for 3 to 6 weeks in running water or permanent water sources

B. Smoking

Smoking is an effective non-chemical treatment method of bamboo. The bamboo is stored above the fireplace for few days until the colour turns into slightly black. However, excessive heat might develop fissure or crack in fresh bamboo, especially when you apply heat to the freshly cut bamboo.

3.2 Chemical Methods

Various chemical preservatives and methods have been applied and suggested. However, two kinds of preservatives that were used in Ghana for the treatment of bamboo are mentioned here.

3.2.1 Coal Tar Creosote Oil

Creosote oil is poisonous and health hazard. One has to avoid direct contact with the exposed body parts. However, it could be an effective preservative if applied properly (using appropriate method). This method is applied only for the round (whole) poles and not for the strips.

Preservation method

The preservative was injected in each internode of bamboo. Oil dispenser (an injecting pot) could be used to inject the oil into the poles.

Procedures

- ◆ Drill 6mm holes in all the internodes (nearby node to avoid culm damage) using an electric or manual drill
- ◆ Pour creosote oil into an oil dispenser (a small injecting pot)
- ◆ Estimate the quantity of creosote oil that can be injected in one squirt. You can determine this using measuring cylinder. The quantity of each ejaculation in this case was 1 ml.
- ◆ Inject 50 ml (50 squirts) in each internode (numbers of squirt, however, depend upon the quantity of creosote in each squirt)
- ◆ After injection, seal drilled holes with paraffin wax.
- ◆ Rotate the pole around and up and down to achieve good coating of internodes. Repeat the process every 3 times a day for 4 days.



Pictures 1-2 Drilling and Injecting Creosote Oil

Precaution

- ◆ Use gloves, goggles and masks while working with creosote.
- ◆ Keep children away.
- ◆ Keep fire away as it is highly inflammable.
- ◆ Wear long sleeved shirt.

Note

- ◆ Make sure to use pure and unadulterated creosote oil for the better result.
- ◆ It is recommended that the holes drilled for the preservation coincide with the position of dowels so as to reduce the amount of drillings.

3.2.2 Borax and Boric Acid (Boron)

Borax and boric acid are tasteless and colourless chemicals. They are known as highly safe preservatives. They can be used for the treatment of both bamboo poles and strips.

Long (3300mm) and short (1100mm) bamboo strips were treated with these chemicals in this project.



Picture 3 Borax and Boric Acid

Preservation Method

The cold immersion method was applied. However, hot immersion and brochure methods are also commonly practised.

Procedures

i) Split bamboo into strips

- ◆ Cut the bamboo into the required length (In this case, 3300 mm for vertical grids and 1100 mm for horizontal grids)
- ◆ Split bamboo using hand splitter or by machine splitter (if available). While using hand splitter, it is centrally placed at one end of the pole and secured into place by initial hammering with a heavy object. Splitting is achieved by hitting the free end of the pole against a firm object such as a rock. The splitter then falls under its own weight, causing the culm to split into strips
- ◆ Make bundles of strips (25 pieces each) and tie them with rope or lash for the easy handling and transportation.



Picture 4: Splitting

ii) Preparing Receptacle (Empty oil container)

- ◆ Cold immersion can be done in any kind of drum, though 900mm high metal drum is preferred.
- ◆ Cut each drum in half (along the length). You will require 2 and ½ numbers of 900mm drum to prepare a 4500 long receptacle.
- ◆ Join and weld half-cut drums.
- ◆ Check leakage by filling with water
- ◆ All sharp parts should be made blunt for safety.



Picture 5: Receptable

iii) Preparation of solution

Boric acid and Borax have to be mixed at the ratio of 1:1.5 in a bowl before introduction into the trough. Make a 2.5% solution with water (1kg of boric acid and 1.5 kg of borax acid for each 100 liter of water). The solution should be thoroughly stirred until the chemicals are fully dissolved in water.

iv) Immersion of bamboo strips

- ◆ Immerse the bundles of bamboo strips in the solution
- ◆ Align them properly in such a way that a lot of bundles could be immersed at a time
- ◆ Put load (ballast) on the top of strips for the better immersion
- ◆ Keep strips immersed for at least 6 hours

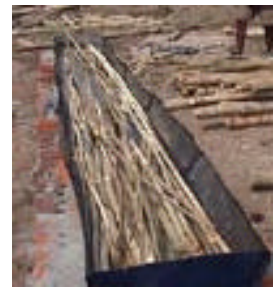

Picture 6: Strips in solution

v) Drying Bamboo strips

The preserved strips are removed and leaned against an upright support for the preservation to drip out as the strips dry. Keep them for about 12 hours in this position.

Note

If bamboo poles were to be treated with Boron, the holes should be drilled in each internode and the solution should be heated to speed up the process. They should be immersed at least for 24 hours.



Picture 7: Strips drying

4. Construction

There are various designs and systems of bamboo construction. This manual, however, has focused on the design that was adopted in Ghana to build a primary school. The system could be adapted in other areas with the local modifications such as technology, cost, manpower and final product requirements.

4.1 Building Plan

- ◆ Draw clear plan and elevation of the building before commencing the construction works or use technical drawings in the annex (Chapter 5)
- ◆ Plan should clearly show dimensions of the total building and each room.
- ◆ It should also show the locations of windows and doors plan and their details
- ◆ Elevation should show the total height of the building, the depth of the foundation and slope of roof.
- ◆ Add ramp and avoid steps if wheel chair access is necessary

Details of the Ghana school

- ◆ 3 rooms; each of 7.2m length and 6m width.
- ◆ 2.4m wide veranda in one side of the building
- ◆ 2 toilets of 2.4m width and 3.6m length.
- ◆ The dimensions (length and width) of the building or rooms are in multiples of 1.2m (the spacing between bamboo columns).
- ◆ The room height (between floor and underside of roof truss) is between 3.3m and 3.6m. This was done to suit the slope of the site (you will not find this height difference in the technical drawings in Chapter 5)
- ◆ Refer technical drawings in the annex with slight changes to the Ghana school (room height, ramp)

4.2 Sub-structure (Foundation)

Foundation is an important structure of building. It should be strong enough to bear the whole building load. The foundation work includes layout, clearing digging, filling and levelling.

4.2.1 Foundation Layout -

This is done to layout the digging area of foundation and should be done according to plan of the building.

Materials required

- ◆ Long rope (preferably nylon)
- ◆ 150mm or 6" long nails or iron or wooden pegs (the number required depending upon the size of the building)
- ◆ Measuring tape (30m or 50m)
- ◆ 3-4-5 right angled wooden structure

Fixing the building corners and marking excavation areas

- ◆ Use your judgement for the alignment of the building. It can be done using reference from road or neighboring building (so that the building will be aligned properly).
- ◆ Decide the first corner (corner A in figure 3) of the building and fix nail or peg
- ◆ Use 3-4-5 method (i.e. 3 sides of the triangle measure 3, 4 and 5 feet or meter) to fix the other corners of the building. You can use tape or wooden structure for the purpose. This would ensure the right angle of the corner of the building.



Picture 8: using 3-4-5 method to fix the corners of the building

- ◆ Measure the total length of the building along one side of the 3-4-5 triangle (except along side 5) to fix the peg on the other corner (B).
- ◆ You need to apply this method two opposite corners (A and C in the figure) to fix all the 4 corners.
- ◆ Check the alignment of the building – for this, measure diagonally from one corner to other. The distance of two diagonal measurements (AC and BD) must be equal for square or rectangular layout of the building.

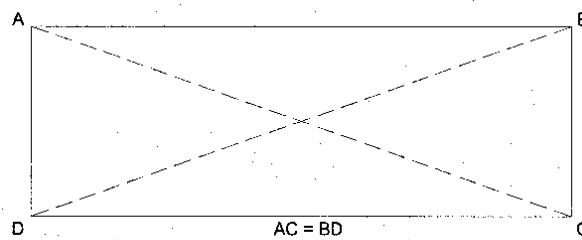

Figure 3: Initial foundation layout

4.2.2 Foundation Excavation

Once the foundation layout is completed, the excavation starts. One need to dig out all soil along the ropes laid during layout phase to the required total foundation depth.

- Excavate from one end by using local available tools
- Keep the excavated soil for future use as backfilling material (if found to be of good quality)
- Dig 45-cm wide and 45 cm deep trenches. However the depth of the foundation will depend upon nature of the ground. If the ground is hard and rocky, the total depth of digging can be reduced to 37.5 cm. In no case however should the foundation depth be less than 37.5 cm. Where there is a slope in the natural ground, the foundation depths can be stepped.

4.2.3 Levelling

In the undulated ground surface, levelling is important so as to achieve levelled (horizontal) ground flooring at the later stage. You can do it using spirit level or transparent water pipe filled with water. The levels of water in the both sides of the pipe show the horizontal level of the ground. You need to take a fixed level in one corner and based on that, the level of other corners can be fixed seeing the water level in pipe. You can mark the level in the peg. The foundation wall will be construction only up to that marked point.



Picture 9: Levelling by transparent water pipe

4.2.4 Foundation wall

Once the digging work is finished, the foundation wall is started. You need to construct wall to a total height 900mm above the trench concrete. However this height may differ according to slope condition of the ground.

- The first layer of the foundation concrete is the 'trench' concrete; of 125 mm thick. This forms the base of the foundation wall. The mix proportions of the trench concrete is 1part of cement to 3 parts of sand to 6 parts of coarse stones (or 1:3:6).
- Construct wall to a required height by using clay brick or sandcrete or large stones. The thickness of wall must be at least 150mm. Use cement mortar of 1:4 (cement and sand) proportion for brick, sandcrete or stone jointing.
- Leave 150mm gap after every 1.2m length of wall for the later construction of foundation base of the bamboo columns.

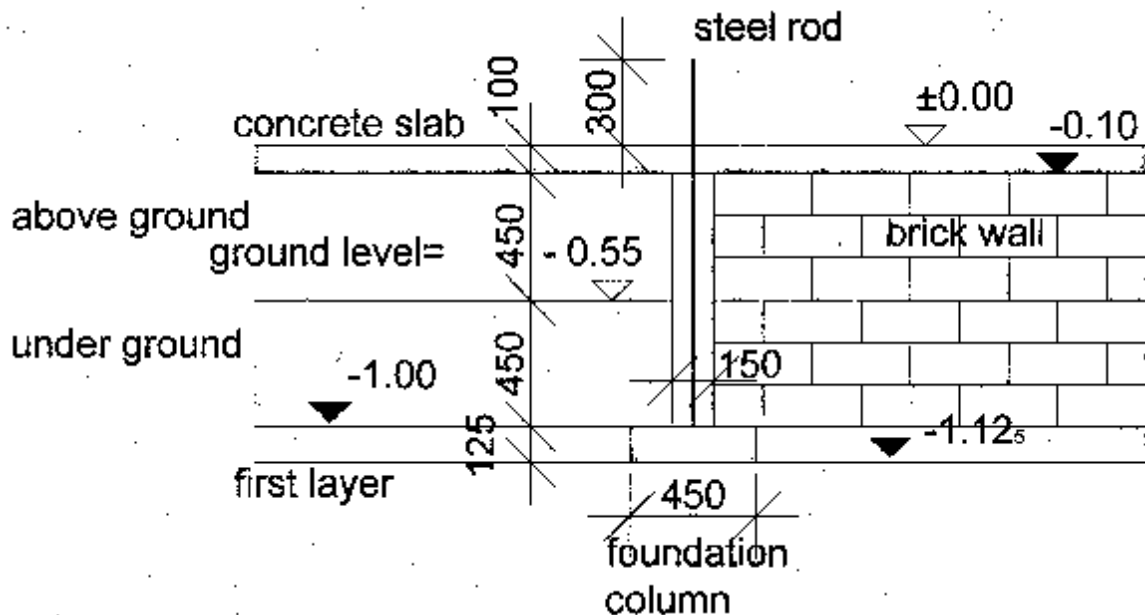

Figure 4: Foundation wall



Picture 9-10: Foundation

4.2.5 Foundation base for bamboo columns

At this point you need to decide whether you want to embed bamboo column in the foundation or not. If the earth surface is marshy and the bamboo is vulnerable to decay due to high moisture, it is generally better to erect the column from above the foundation level with the support of steel dowel embedded in the foundation. This method was applied in Ghana. Such foundation consists of mild steel rods (dowel) buried in concrete and resting on the trench concrete. They are to support the bamboo columns.

- Put 3 iron rods of 8 to 10mm in diameter in the middle of the gap (150mm L x 150mm W x 900mm H) in the foundation wall. The rod (dowels) must protrude to a height of 300mm above the floor slab level. It means the total length of the rod must 1200 (300 above wall+900 under wall) in this case. It may vary according to the depth of foundation.
- Fill the gap with concrete (1:2:4) to make a column. Appropriate timber frame or blocks must be provided as supports (backing) to keep the concrete in place.



Picture 11-12: Foundation column and ground slab

Alternative

Alternatively you can embed the bamboo columns in the foundation with the proper treatment of soil and concrete footing (base) that holds bamboo firmly. This system has been applied at IPIRTI, Banglore, India.

In this case, you don't require to put steel bar in the foundation. Instead, you need 40 x 40 cm x 45 cm space in the foundation to embed the bamboo column which is reinforced with three steel bars. The space is filled with concrete (1:2:4) to hold the bamboo column.



Picture 13: Foundation to embed columns

4.2.6 Back-filling and Ground Flooring (Slab)

After finishing the foundation wall works you need to back fill the foundation using granular sands. Ponding (pouring water) helps to settle faster. For the ground flooring, construct 85-100mm thick ground slab over the settled fill by using 1:2:4 concrete. Please refer picture 12.

4.3 Wall Structure: Prefabrication stage

4.3.1 Drilling

Drilling of dowel holes in the bamboo column should be done during the prefabrication (before erecting them) stage. The holes receive horizontal dowels during the wall construction.

For the purpose, appropriate size treated bamboo column (refer section 2.5 for size and 3 for treatment) are selected.

- ◆ Mark the bamboo at 30cm height from the bottom and drill straight through both sides. 30cm free portion was reserved for the vertical foundation dowel and concrete filling.
- ◆ After the first mark (drill), mark the bamboo at every 15cm and drill them both sides (straight through).
- ◆ Use 8-10mm (diameter) drill so that similar size of steel dowel could be inserted later
- ◆ To make easier to mark many bamboos together, keep them on the ground next to each another and use a marked stick to mark them simultaneously.

Note

- ◆ Don't drill the columns that are to be used in veranda.
- ◆ Mark and drill the bamboos in two perpendicular directions that are to be used in the corners of the building.

4.3.2 Hardwood Plugs

Wooden plug is fixed on the top of bamboo column on which wall plates will be fixed later. The plug also acts to take most of the compression load from other building components.

The wooden plug is a hardwood. The minimum size of the plug is 50mm x 50mm x 150mm. However, the size may vary according to the diameter of bamboo and length of the last internode. The plugs are fixed to the culm through 8 – 10mm diameter steel bolts.



Figure 5/Picture 13: Wooden plug

Alternative way of fixing

The bolting of plugs may be expensive and may consume a lot of time. To minimize the cost and time consumption, you can use plugs which length is equal to the length of internode where it would be inserted. The diaphragm (node) would hold the plugs. Additionally you can nail it to fix it properly. However, bamboo might split due to nailing.

4.4 Wall Structure: Fabrication stage

4.4.1 Erection of Bamboo Columns

Column is the main load bearing part of the building. All the columns are bamboos that are fixed with the foundation concrete through steel rod. Distance between two columns is 1200mm center to center except for the veranda where the distance between two columns is 2400mm center to center. To fix the column, you need to

- ◆ Fill the one end of bamboo hole (internode length >300mm) with cement mortar. If the internode length is shorter than 300mm, break the lowest diaphragm to increase its length
- ◆ After filling cement concrete mortar (1:2:4), close the mouth of bamboo using your hands to prevent spilling out
- ◆ Slowly upend the bamboo pole over the vertical dowel with no loss of concrete and upright the bamboo vertically
- ◆ Shake the bamboo from all directions for concrete to well set with steel rod
- ◆ Brace the bamboo column into two perpendicular directions for almost all the period of wall construction
- ◆ Wait 3 to 5 days before doing further works in order to give enough time for columns to be settled.



Pictures 14a,b,c: Bamboo column

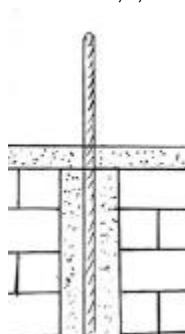

1

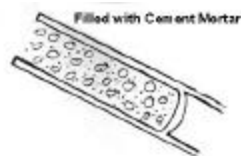

2

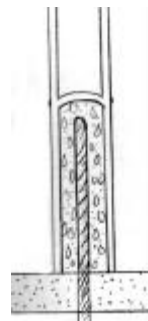

3

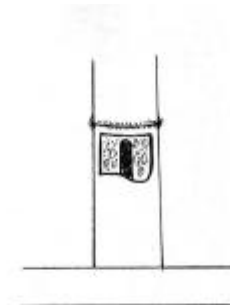

4

Figure 6: Fixing bamboo column

Alternative

The above method is applied if you don't want to embed the bamboo columns in the foundation. It should be applied especially in the marshy areas where the bamboo is highly vulnerable to decay due to moisture. However, you can also embed the bamboo in case, you don't require embedding the steels dowel in the foundation. The picture shows embedding a bamboo column in the foundation using cross reinforcement and concrete footing.



Picture 15: Embedding bamboo column

4.4.2 Brick or Block plinth (Damp Proof Course)

Twelve (12) hours after fixing the columns, a course of block plinth of 225 high is laid down between the columns. It acts as a barrier between the bamboo strip grid and concrete floor slab. This prevents direct contact of strips with damp floor so also acts as dam proofing.



Picture 16: A course of block plinth

4.4.3 Wall plate

Wall plates are hard wood of 50 (B) x 100 (W) mm size. It ties bamboo columns together and put them in the right alignment. It also provides lateral support to the top of the pole and provides a seat for roof trusses, ceiling, joists and clamping devices. Wall plates are fastened to poles through 100mm screws into hardwood plugs.

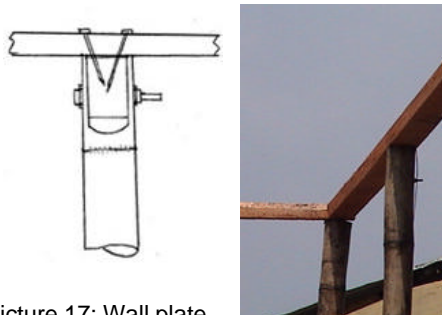

Figure 7/Picture 17: Wall plate

4.4.4 Construction of Wall Panels



Wall consists of steel dowels bamboo columns, bamboo strips, chicken mesh and cement plaster.

Bamboo wall grids

Bamboo grids are the main wall supporters. Bamboo strips are tied with steel bar (dowel) to form grids. To prepare grids, you need to

- ◆ Insert 300mm long steel rod of 8-10mm diameter in bamboo columns at 15cm spacing (information about drilling holes in bamboo so as to insert these rods are already provided in section 4.3.1)
- ◆ Tie bamboo strips (15-25 mm width) to the horizontal steel dowel rod of two consecutive columns. Use binding wire to tie the strips with steel rods
- ◆ Once the horizontal parts are finished, fix the vertical strips again at 15cm spacing. You can tie vertical strips with horizontal strips. The top end of vertical strips can be tied to nails fixed to the wall plates.
- ◆ Make sure to leave gaps for doors and windows.

Note: The outer (hard) face of both horizontal and vertical strips has to face inside.



Picture 18-19: Bamboo wall grids

Fixing Chicken (Wire) Mesh

After fixing bamboo strips, one needs to fix chicken mesh on one side of the strips, generally exterior part of wall. The chicken mesh is tied to the steel dowel and with the bamboo strips using binding wire. The wire-mesh holds the mortar and also prevents the development of shrinkage cracks in the cement mortar.

Note: If you don't want to cover bamboo columns with cement plaster, then don't put chicken mesh around it.



Picture 20: Fixing chicken mesh

Plastering (Wall Cladding)

After fixing chicken wire mesh, the grid is plastered with cement sand mixture (1:3) to the both sides of the wall.

- ◆ First do plaster the interior part of the wall. Use backing (some supporting material) such as bamboo mats or plywood on the other sides of the wall to prevent spilling out of cements mortar.
- ◆ The first plaster is rough which intend to fill the grid space.
- ◆ Humidify the plaster at least twice a day for the better bonding of mortar
- ◆ After 48 hours, the second smooth plaster can be done on the both sides of the wall.

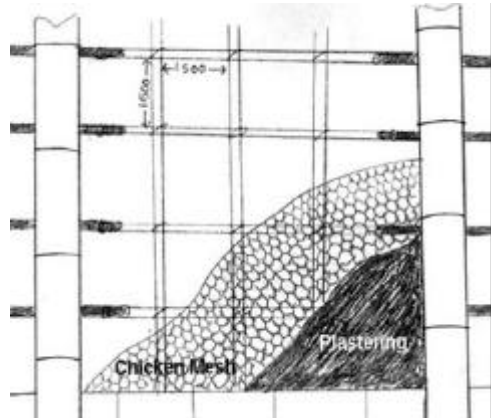
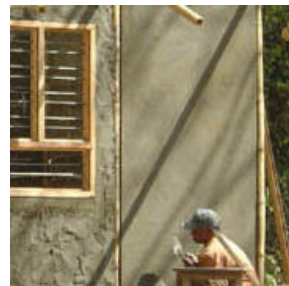

Figure 8: Wall structure



Picture 21-22: Rough and smooth plastering

4.4.5 Doors and Windows

The dimensions of doors and window may vary according to the situation and designs. In case of Ghana, the dimensions of the windows are 1100mm (W) and 1300mm (L) and those of doors are 1100 (W) and 2100 (L) long respectively. Door and window frames can be made up of wooden frames or bamboo mats. However, wooden frames were used in Ghana, as bamboo mats are not available in the market.

The door and window frames are hanged to the bamboo columns by driving the 125mm nail through the vertical frame member and into the column. The nails are driven at 300mm (12") centres along the height of the frame. Along the horizontal members of the frame, the nail can be driven in half-way through the frame from the outside. The remainder of the nail will act as a key (dowel) when the cement mortar plaster is being applied.

The height of the bottom of the window from the ground floor slab is 900 mm and this is chosen by example of similar classroom buildings and the width of the chicken wire (900 mm).

Note: Door or window frames must be hanged before plastering the walls.

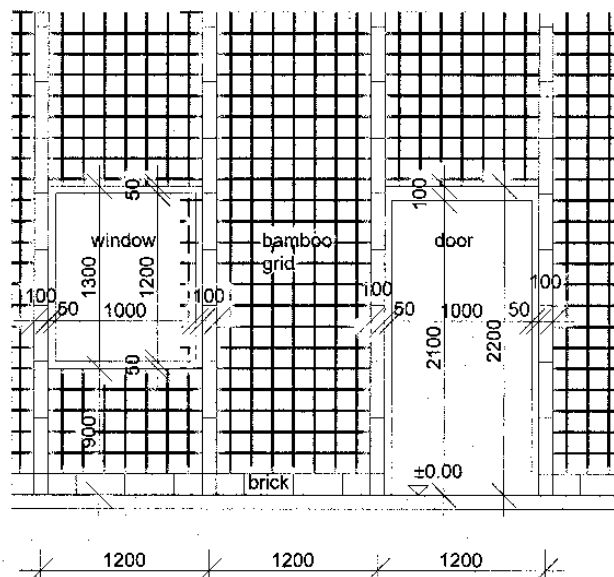

Figure 9: Door and window

4.5 Roof

Roof is made up of bamboo trusses, hardwood purlins and roofing sheets.

4.5.1 Roof Trusses

Trusses are generally installed at 2.40m apart on the roof so as to coincide with the column position. So, dividing total length of a building by 2.4 you can easily calculate the number of trusses required for a house.

Dimensions

The dimensions of a truss may vary with the width of the building. In any case the total base length should be equal to the width of the building. Moreover, the dimensions of other members of a truss depend upon the pitch or angle of the truss. Generally the height of the trusses are 1/4 to 1/6 of the total length of the trusses.

As the width of the Ghana school is 8.4m that makes the length of the trusses as well. However, 65cm additional slopes were provided on both sides for overhanging, hence making total length 9.7m.

In the Ghana school case, a 15° pitch or 3.7 horizontal to 1 vertical has been used. This slope is the least that can be used if the roof is not to be easily blown away by winds and to reduce unused roof space.

Please see the dimensions of each member of a truss (in Ghana case) in the following figures.

Tools required to assemble trusses

- ◆ Drilling Machine
- ◆ 6mm gusset plates made up of plybamboo or plywood
- ◆ Hand saws
- ◆ Nail and wires
- ◆ 10mm and 12mm diameter Bolts (30 number for each truss)
- ◆ Spanners and screw drivers
- ◆ Hard wood plugs

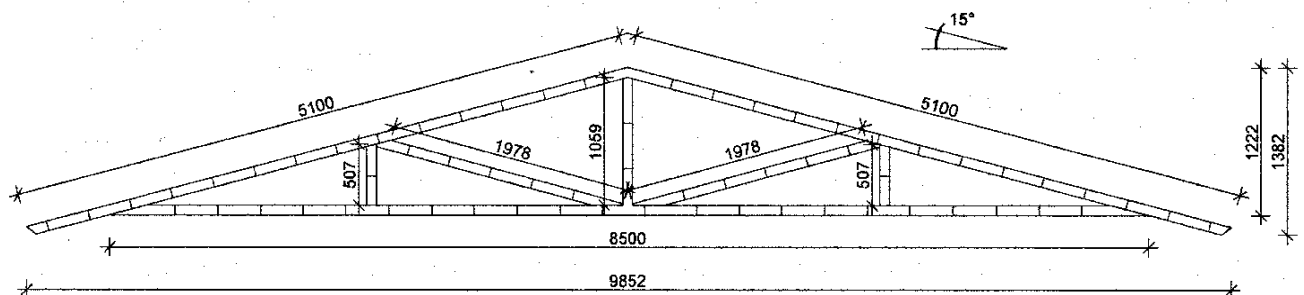

Figure 10: Truss

4.5.2 Assembling a truss (For a 9852 mm long, 15° pitch)

- ◆ Select bamboo poles suitable for the truss. Preferred diameter is 80 to 90mm and the wall thickness is 10mm. Please refer to the section – for the details.
- ◆ There are total of 8 members of round bamboo required to assemble a truss. The longest truss member is 8500 mm. As it is difficult to find a 8500 mm long bamboo, select 2 each of 4250 mm length.

◆

Length of a member	Number required
Ca. 8500 mm	1 (or 2 of 4250 mm)
Ca. 5100 mm	2
Ca. 1060 mm	1
Ca. 2000 mm	2
Ca. 510 mm	2

- ◆ Cut both ends of the bamboo members to a shape required for jointing. For example, for the right angle jointing, one end of the vertical member requires to be fish mouth shape.
- ◆ In each open end, insert a wooden plug for better jointing. However, if the member end coincides with bamboo node, insertion of a wooden plug may not be necessary.
- ◆ Assemble each member of bamboo as shown in figure.
- ◆ Prepare gusset plates; 8 pairs of plates of different sizes are required for a truss. Determine the size of plates according to the shape of joint and the number of members to be joined.
- ◆ Drill through the gusset plate and bamboo together. If a wooden plug is inserted, the plug is drilled through at the same time. This process ensures that the drilled holes are in line.
- ◆ Bolt all the holes.

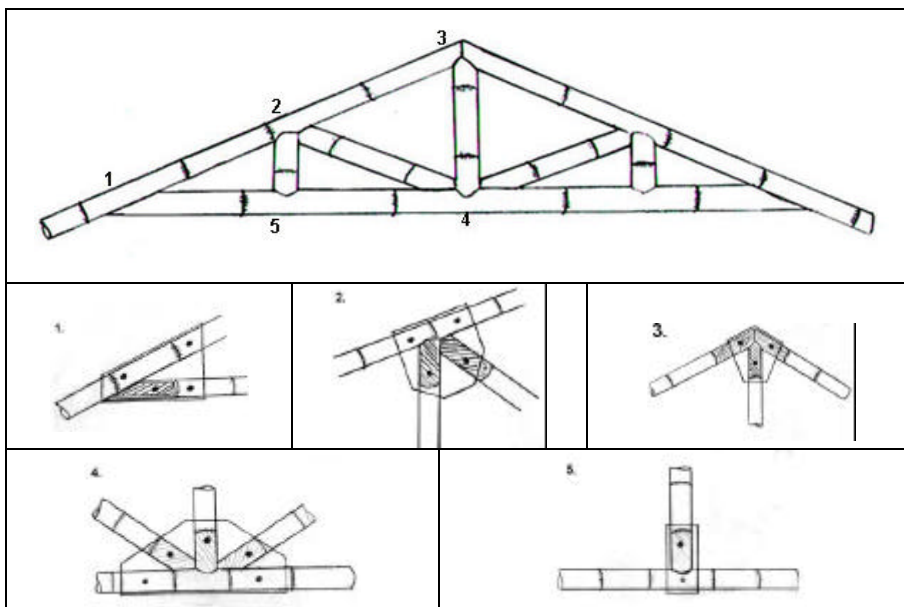

Figure 11: Truss Joints



Pictures 23-24: Trusses and a joint

4.5.3 Trusses Anchorage

Trusses can be installed manually or by using crane. However, if available and affordable, crane is preferred for the safety and efficiency.

- ◆ Use pair of steel L brackets (angle plates) and 12mm bolts to hold down truss to the wall plates at each end of the truss.
- ◆ Use U clamps (as shown in the picture) or holding down bolts to secure the trusses to the wall plates in between the end L brackets; if the bottom chord of the truss sits on a wall plate throughout. Two U clamps are sufficient for each truss.

Note: In the absence of U clamps 10mm diameter reinforcement bars can be folded around the bottom chord of the truss and the wall plate.



Pictures 25-26: Truss hanging and fixing



Pictures 27-28: L Bracket and U clamp

4.5.4 Purlins

Purlins are important to support the roof covering. They are laid down at right angle to the truss. It is possible to use half-culm or smaller diameter round bamboo (30-40mm) or wood as purlins. In this case, 50 X75 mm hardwood was used as purlin.



Pictures 29: Fixing purlins

- ◆ The purlins are fixed to the trusses through nail or binding wire. Binding wire is better as nail might split the bamboo truss.
- ◆ The purlins could be stopped from further sliding down the truss if a 12mm deep rebate (notch) is made at the contact area of purlin to truss.
- ◆ If you are using smaller diameter bamboo as a purlin, you don't need to make notch (rebate). you can simply bind them using binding wire as shown in the picture.

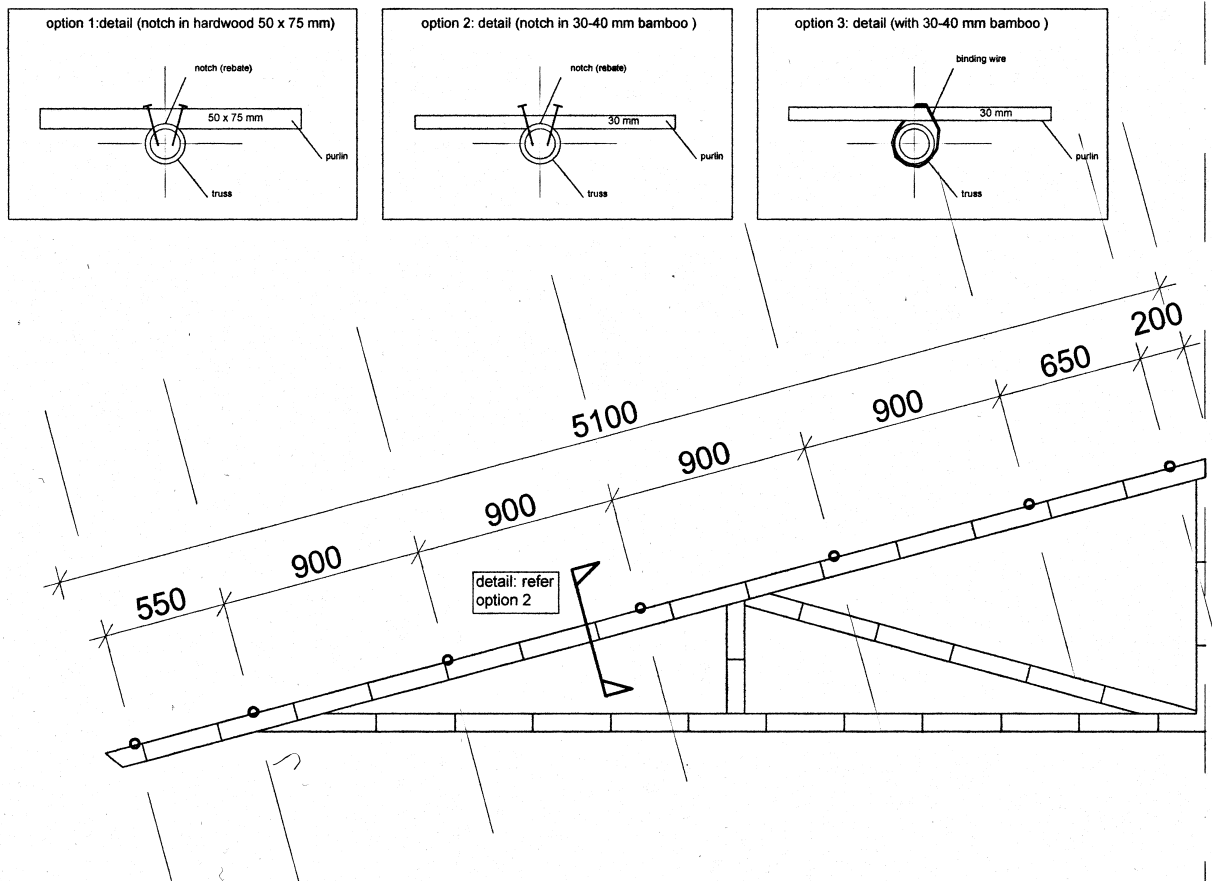

Figure 12: Purlins

4.5.5 Roof Covering

Roof covering may be of bamboo-corrugated sheets, aluminium sheets or any other materials according to their availability and affordability. In this case aluzinc sheets were used as roof covering. These types of sheets are known to provide a cool ambient atmosphere to rooms.

The sheets were held to the purlins by J bolts that are incorporated with washers for prevention of rain leakage through the nail points.



Pictures 30-31: L Fixing roof cover

4.6 Finishing

After the completion of the structure, you can do finishing works such as painting, electrification, toilet, gardening and drinking water supply. The quantity and quality of the finishing works depend upon the requirements and financial situation.

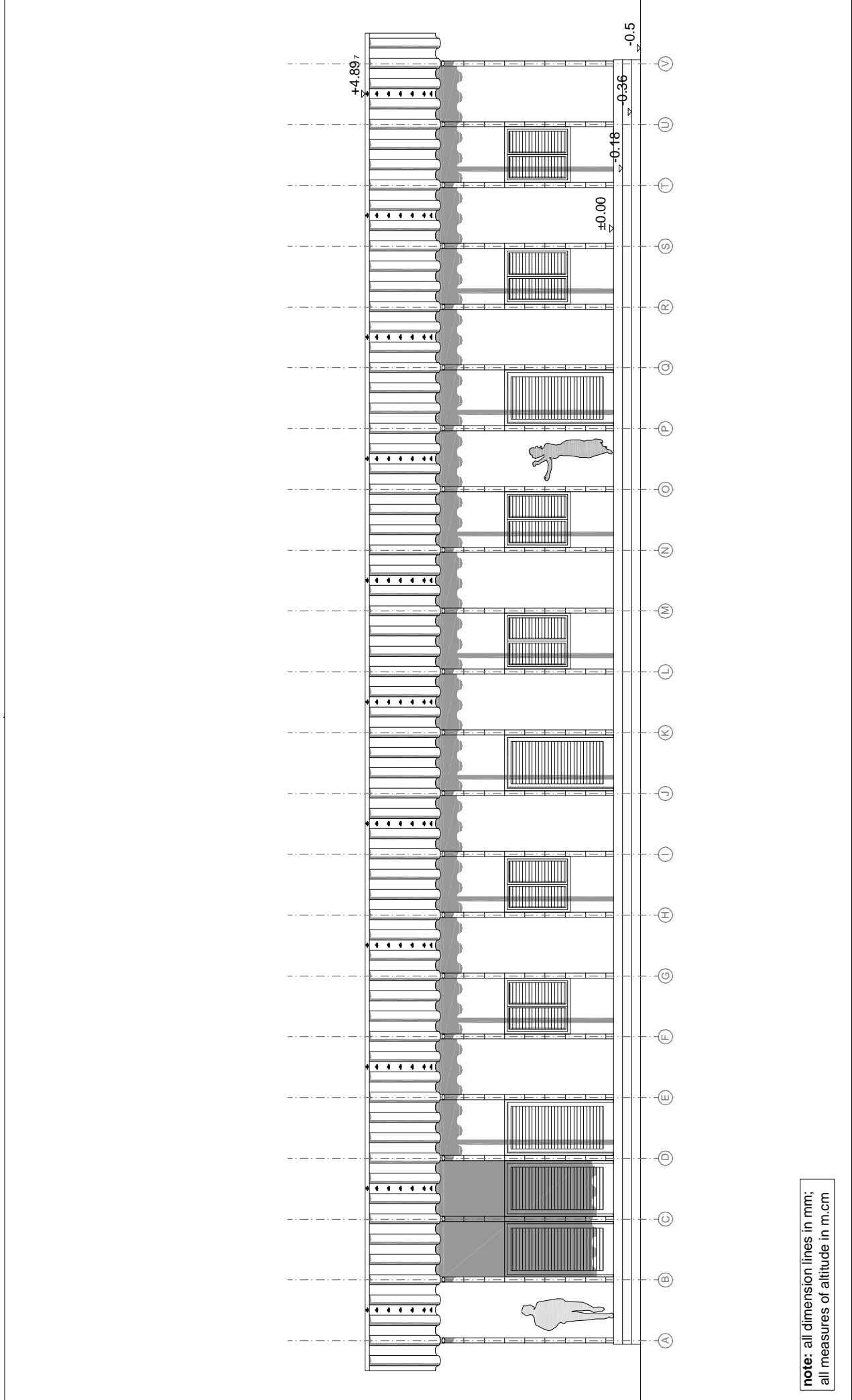

note: all dimension lines in mm;
all measures of altitude in m.cm

CHRISTIAN BORCHARD
ARCHITECT
KOLLWITZSTRASSE 100
D - 10435 BERLIN
WWW.CHRISTIANBORCHARD.DE

date 15 February 2005
N° 1.01
scale 1 / 100

veranda / front elevation

bamboo school building
International network of bamboo and rattan
INBAR

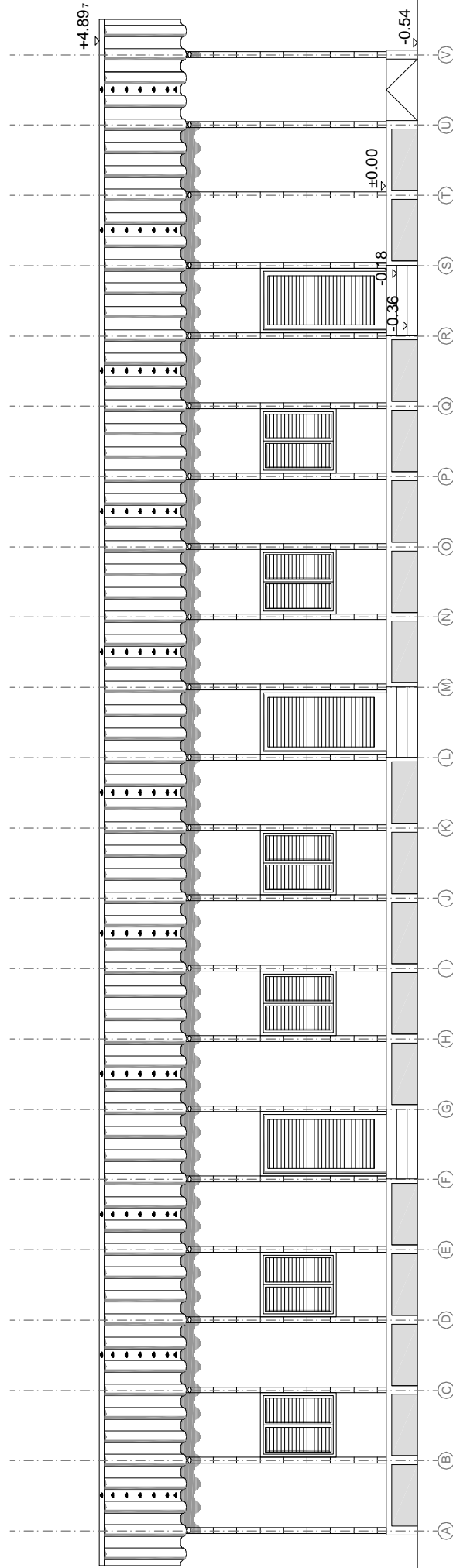

note: all dimension lines in mm;
all measures of altitude in m.cm



bamboo school building
International network of bamboo and rattan

rear elevation

date 15 February 2005

N° 1.02
scale 1 / 100

CHRISTIAN BORCHAR
ARCHITECT
KOLLWITZSTRASSE 10
D - 10435 BERLIN
WWW.CHRISTIANBORCHARD.D

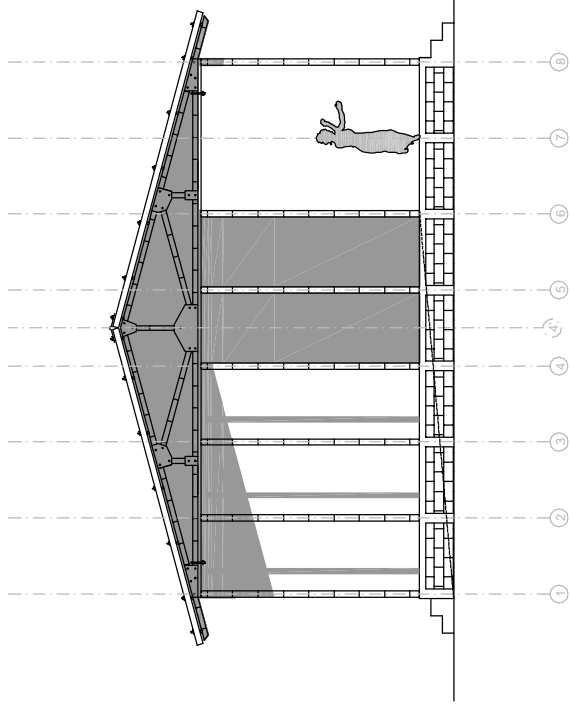

side elevation axis A

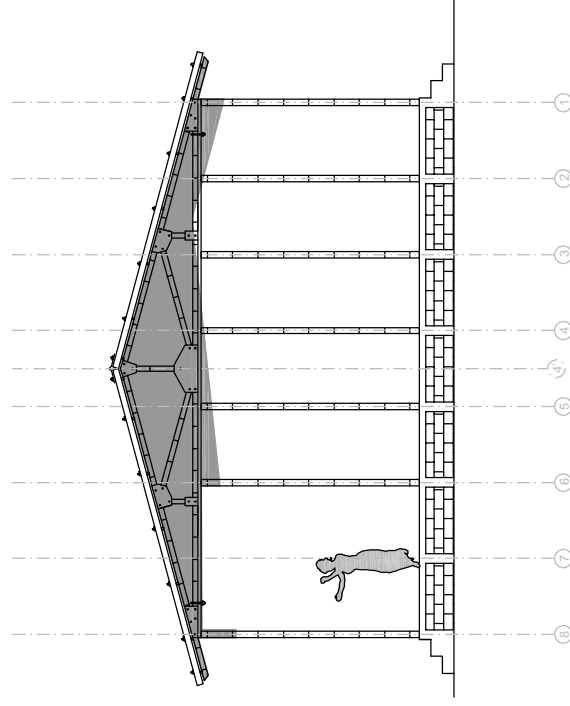

side elevation axis V

note: all dimension lines in mm;
all measures of altitude in m.cm



bamboo school building
International network of bamboo and rattan

side elevations

date

15 February 2005

N°

1.03

scale

1 / 100

 **CHRISTIAN BORCHARD**
ARCHITECT
KOLLWITZSTRASSE 100
D-10435 BERLIN
WWW.CHRISTIANBORCHARD.DE

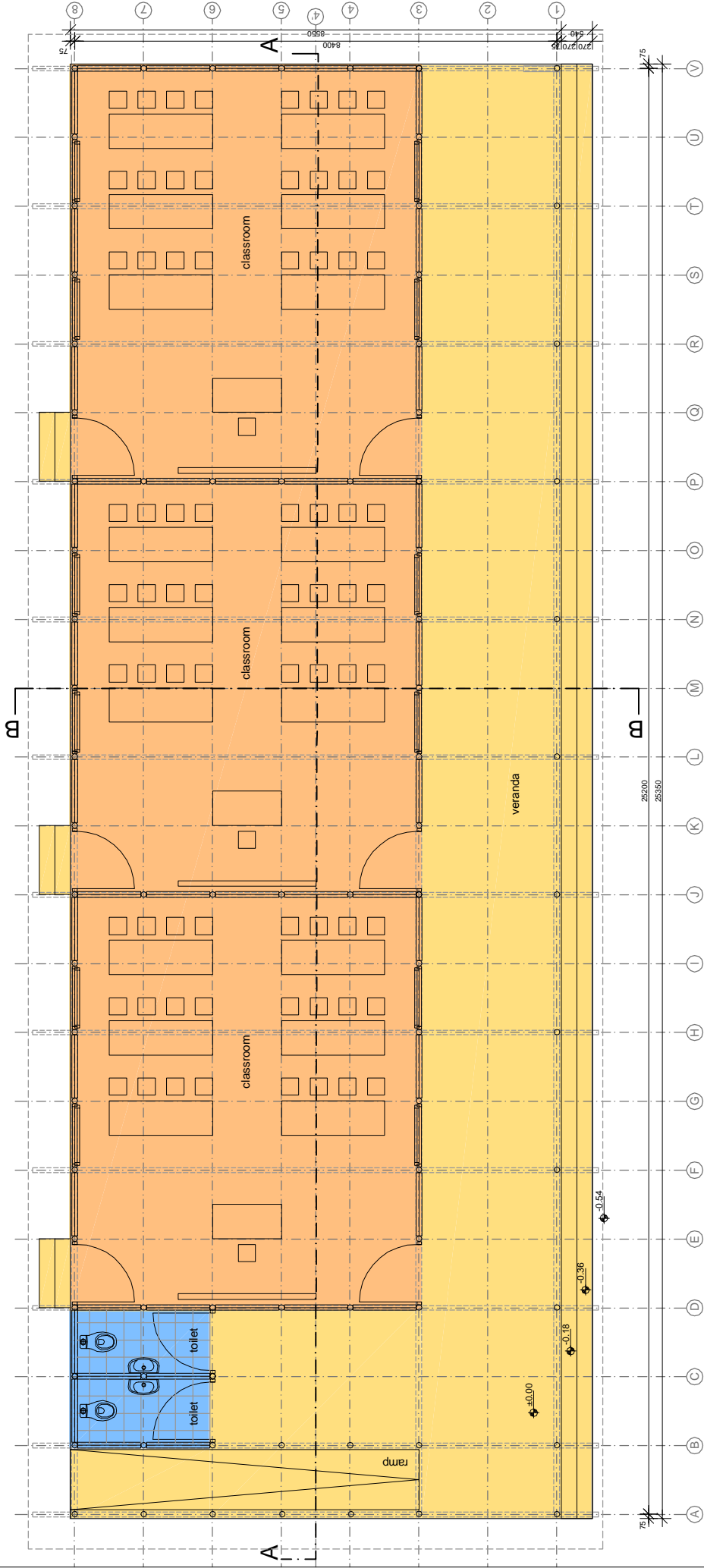

note: all dimension lines in mm;
all measures of altitude in m.cm

date 15 February 2005

N° 1.04
scale 1 / 100

plan 1/100

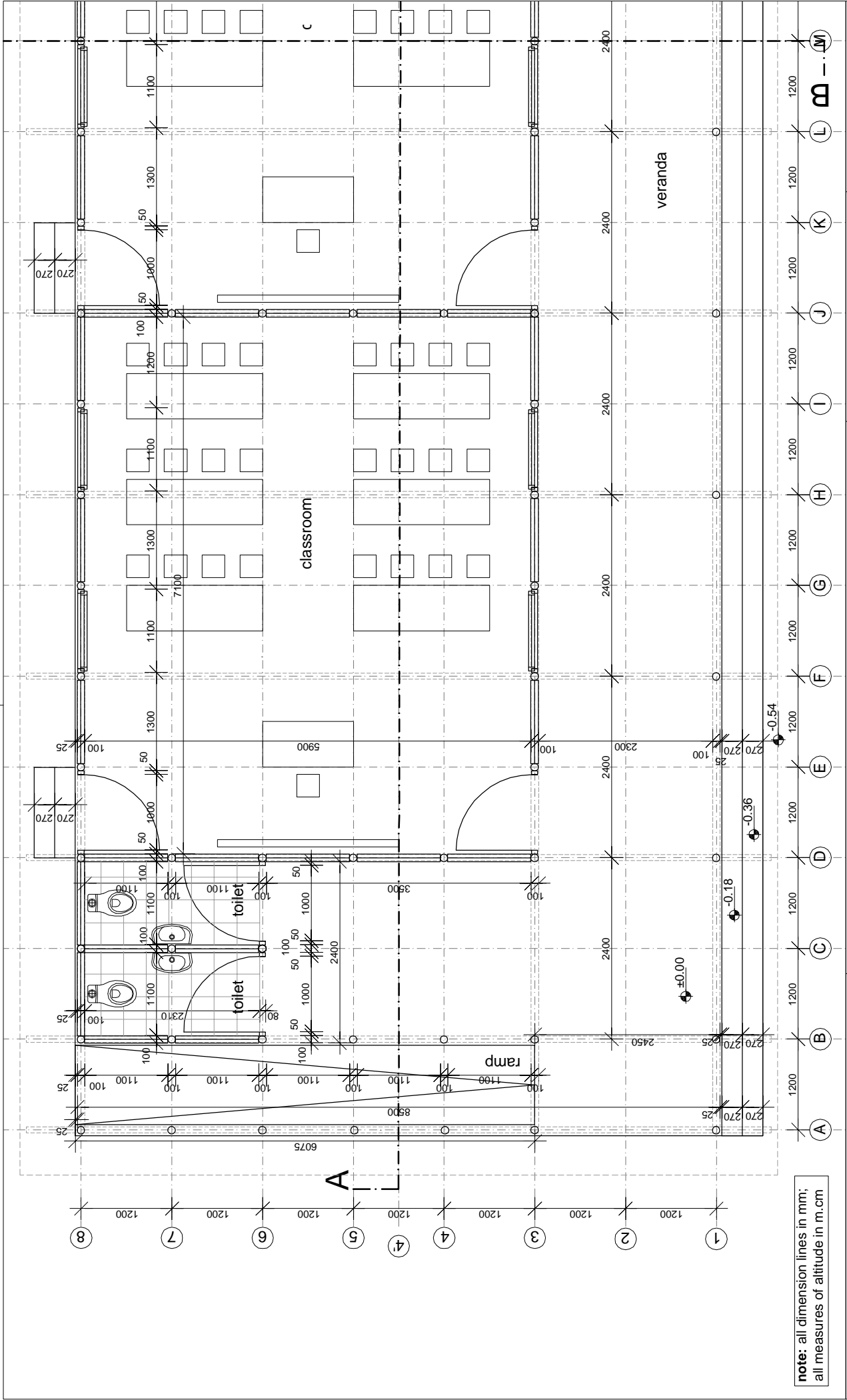

note: all dimension lines in mm;
all measures of altitude in m.cm

CHRISTIAN BORCHARD
ARCHITECT
KOLLWITZSTRASSE 100
D - 10435 BERLIN
WWW.CHRISTIANBORCHARD.DE

date 15 February 2005

N° 1.05
scale 1 / 75

plan 1 / 75 axis A-M

bamboo school building
International network of bamboo and rattan



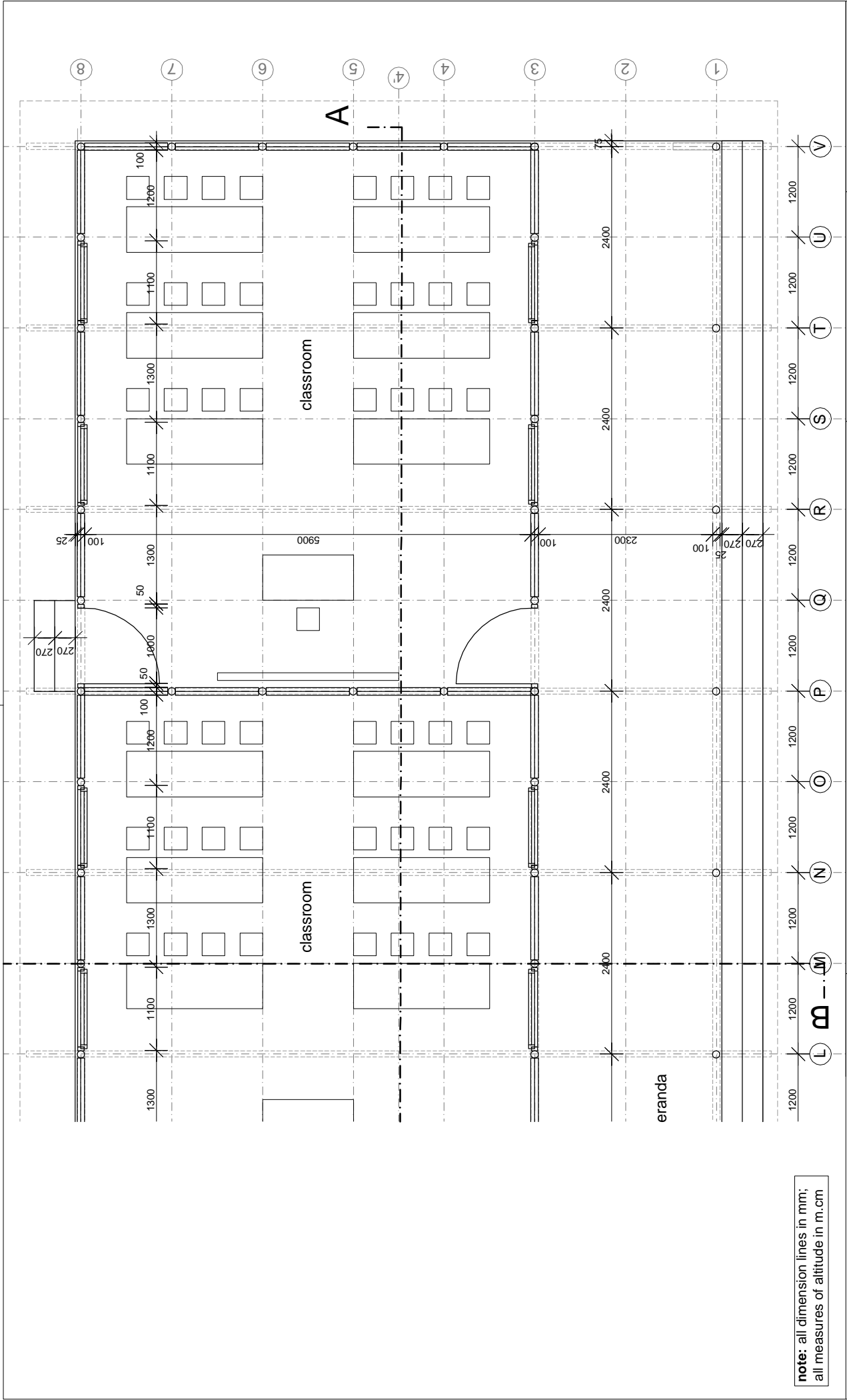

note: all dimension lines in mm;
all measures of altitude in m.cm

CHRISTIAN BORCHARD
ARCHITECT
KOLLWITZSTRASSE 100
D - 10 4 35 BERLIN
WWW.CHRISTIANBORCHARD.DE

date 15 February 2005

N° 1.06
scale 1 / 75

plan 1 / 75 axis M-V

bamboo school building
International network of bamboo and rattan



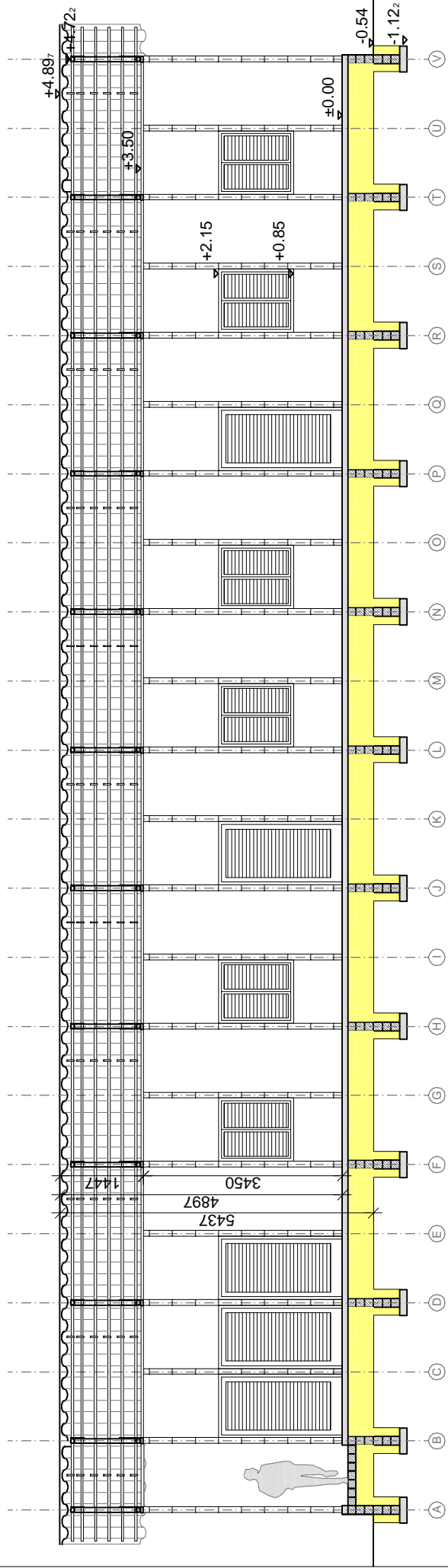

-  cement mortar
-  concrete
-  granular sand
-  wood

note: all dimension lines in mm;
all measures of altitude in m.cm

CHRISTIAN BORCHARD
ARCHITECT
KOLLWITZSTRASSE 100
D - 104 35 BERLIN
WWW.CHRISTIANBORCHARD.DE

date 15 February 2005

N° 1.08
scale 1 / 100

section A-A

bamboo school building
International network of bamboo and rattan



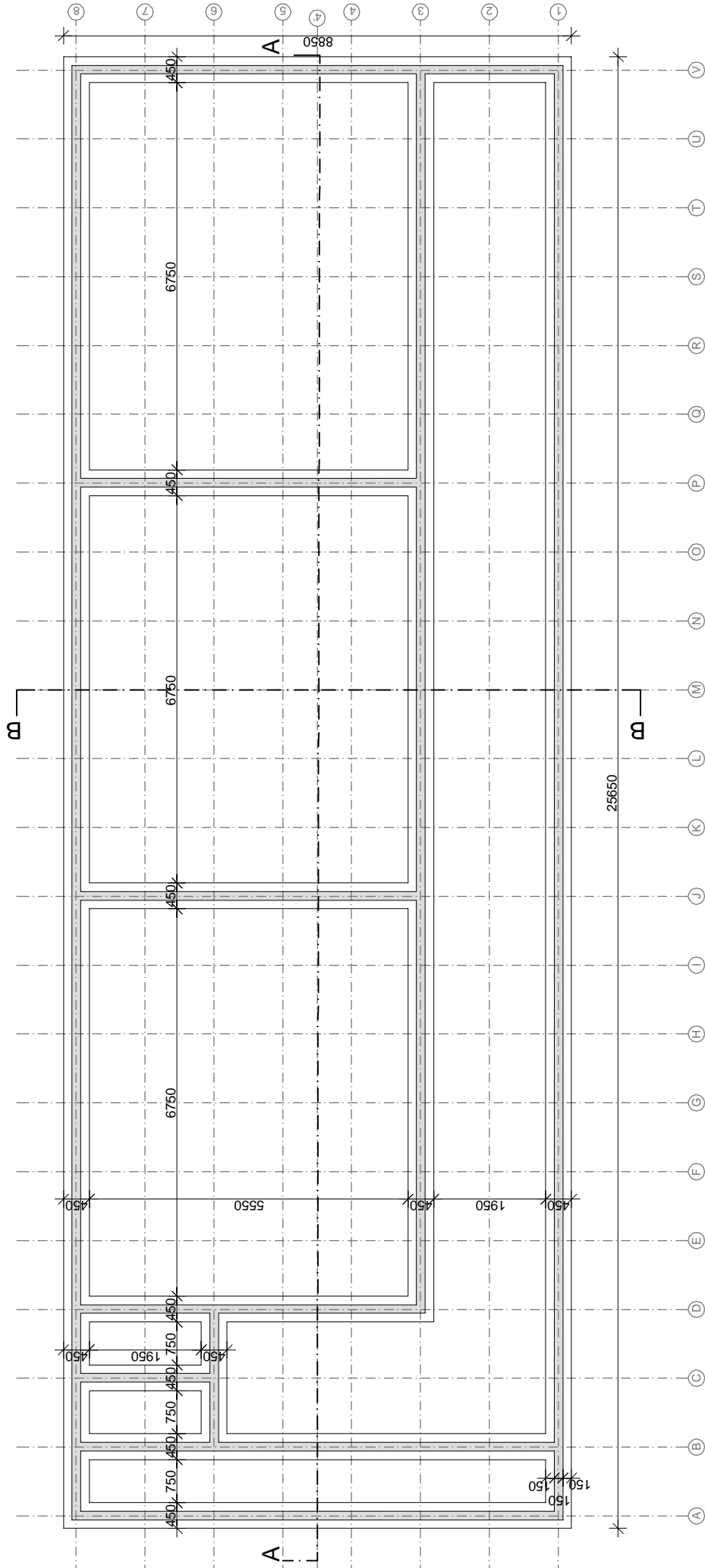

note: all dimension lines in mm;
all measures of altitude in m.cm



bamboo school building
International network of bamboo and rattan

foundations

date 15 February 2005

N° 1.00
scale 1 / 100

Reading Materials

1. Gutierrez J.A. 2000. Structural Adequacy of Traditional Bamboo Housing in Latin America. INBAR technical report no. 19.
2. Janssen J. A. 1988: Building with Bamboo. University of Eindhoven, The Netherlands
3. Janssen J.A. 2000 : Designing and Building with Bamboo. INBAR Technical Report No 20.
4. Janssen J.A. 2000: Building with Bamboo: A handbook. Intermediate Technology Publications limited. 103-105 Southampton Row, London WC1B 4HH, UK
5. Diane Diacon (1998) Housing the homeless in Ecuador: Affordable housing for the poorest of the poor. Published by Building and Social Housing Foundation, Memorial Square, Coalville, LE 67 3UT, UK
6. Janssen J. A. 1991: Mechanical Properties of Bamboo. Eindhoven University of Technology. Published by Kluwer Academic Publishers, the Netherlands.
7. Jayanetti D. L. and Follet P. R. 1998 : Bamboo in Construction: An introduction. Published by TRADA and INBAR for DFID
8. Bamboo for Sustainable Development (1998):. Proceedings of the 5th International bamboo congress and the 5th International Bamboo workshop. INBAR proceeding No. 7. Editors: Kumar A., Ramanuja Rao I.V. and Sastry C. B.
9. Bamboo Current Research (1988) Proceeding of the International Bamboo Workshop November 14-18, 1988 Cochin, India. Editors: I.V. Ramanunja Rao, R.Gnanaharan and Charla B. Sastry.
10. Bamboo, People, The environment (1995) Vol. 3. INBAR Technical report No. 8. Editors: Ramanuja Rao I.V. and Sastry C.B. (Ed.)
11. INBAR: Transfer of Technology Model (TOTEM): Low Cost Bamboo based houses: Viviendas Del Hogar de Cristo, Guayaquil, Ecuador.
12. Jorge Moran Ubidia: Building with Bamboo: A Doing yourself Manual. Special Edition for Workshop in Aizahal (Indian) Organized by INBAR and UNIDO-CBCT
13. Jorge Moran Ubidia: Traditional Bamboo Preservation method in Latin America (2003)-
14. IPITRI: Bamboo Housing Construction Techniques: Do it yourself