



THE HONG KONG
POLYTECHNIC UNIVERSITY

TECHNICAL REPORT NO.23

Design of Bamboo Scaffolds

K F Chung and S L Chan



INBAR



INTERNATIONAL NETWORK FOR BAMBOO AND RATTAN

The International Network for Bamboo and Rattan (INBAR) is an intergovernmental organization established in 1997 by Treaty. As of January 2003, 21 countries (Bangladesh, Benin, Bolivia, Cameroon, Canada, Chile, China, Colombia, Cuba, Ecuador, Ethiopia, Ghana, India, Indonesia, Kenya, Malaysia, Myanmar, Nepal, Peru, The Philippines, Sierra Leone, Sri Lanka, Tanzania, Togo, Uganda, Venezuela, Vietnam) have become INBAR's member countries. INBAR's mission is to improve the well being of producers and users of bamboo and rattan within the context of a sustainable resource base by consolidating, coordinating and supporting strategic as well as adaptive research and development. INBAR program link partners from the technologies that directly improve the well being of people in developing and developed countries.

INBAR publishes an ongoing series of Working Papers, Proceedings and Technical Reports, occasional monographs, reference materials and the INBAR Newsmagazine. It also provides an on-line library featuring relational databases on bamboo and rattan products, organizations, projects, experts and scientific information.

Financial support for INBAR's programs is provided by the Governments of China and the Netherlands, the International Development Research Center (IDRC) of Canada, and the United National International Fund for Agricultural Development (IFAD).

Address:

Anyuan Building No. 10, Anhui Beili, Asian Games Village
Chaoyang District, Beijing 100101, People's Republic of China
Tel: +86 (10) 64956961, 64956978, 64956982
Fax: +86 (10) 64956983
E-mail: info@inbar.int
Website: <http://www.inbar.int/>

Mailing Address:

Beijing 100101-80, People's Republic of China

The Research Centre of Advanced Technology in Structural Engineering (RCATISE) of the Hong Kong Polytechnic University was established in 1999 to provide a focused platform for research and development of advanced technologies in structural engineering in the South East Asia.



Further information about the **RCATISE** may be obtained at the RCATISE web address:
<http://www.cse.polyu.edu.hk/research/rcatise/home.htm>

Disclaimer

Copyright © 2002 INBAR & The Hong Kong Polytechnic University.

All rights reserved. No part of this publication may be reproduced, stored in a retrieval system, or transmitted in any form or by any means, electronic, mechanical, photocopying, recording or otherwise, without the prior written permission of the publisher.

No responsibility is assumed for any injury and/or damage to persons or property as a matter of products liability, negligence or otherwise, or from any use or operation of any methods, products, instructions or ideas contained in the material herein.

Printed by : Colour Max Commercial Printing Company Limited.

ISBN : 962-367-367-1

Foreword

Bamboo scaffolds have been widely used in construction applications in South East Asia, in particular, Hong Kong for many years. Because of their high adaptability and low construction cost, bamboo scaffolds can be constructed in different shapes to follow any irregular architectural features of a building within a comparatively short period of time. In general, bamboo scaffolds are mainly used to provide access of workers to different exposed locations to facilitate various construction and maintenance process. Besides widely erected on construction sites, bamboo scaffolds are also used in signage erection, decoration work, demolition work and civil work.

In 1999, a research and development project titled '*Bamboo Scaffolds in Building Construction*' was undertaken at the Research Center For Advanced Technology in Structural Engineering (*RCATISE*) of the Hong Kong Polytechnic University with the support of the International Network of Bamboo and Rattan (*INBAR*). A Steering Committee was set up as follows:

Co-chairmen

- HKPolyU Co-chairman
Professor J.M. Ko, the Hong Kong Polytechnic University, Hong Kong, and
- INBAR Co-chairman
Professor J.J.A. Janssen, the Eindhoven University of Technology, the Netherlands

Members

- Dr V.N. Gore, GeoScience Services, India
- Professor J. Gutierrez, Universidad de Costa Rica, Costa Rica
- Dr D.A. Tingley, Wood Science and Technology Institute, U.S.A.
- Professor X.J. Xian, the Hong Kong Polytechnic University

Ex-officio members

- Professor S.L. Chan, the Hong Kong Polytechnic University
- Dr K.F. Chung, the Hong Kong Polytechnic University

Invited Members

- Mr Y.S. So, Wui Loong Scaffolding Works Co. Ltd., Hong Kong
- Dr S.P. Chiew, Nanyang Technological University, Singapore

The major objectives of the project are to promote the effective use of bamboo scaffolding in building construction through advancement and dissemination of structural bamboo technology. Both the established knowledge and the proven practice of bamboo scaffolding in Hong Kong are formalized and documented as follows:

- a. *Erection of Bamboo Scaffolds* covering material selection, typical configurations with details, and erection procedures for builders and scaffolding practitioners.
- b. *Design of Bamboo Scaffolds* covering material requirements, typical applications, structural principles and safety requirements for structural engineers.

Other activities include the investigation on modularization of bamboo scaffolds, and the search for improved structural forms using the integrated analysis and design software *NAF-*

NIDA (which is specifically developed for stability analysis of slender skeletal structures). Moreover, engineered connections are also developed for improved buildability and rational data for design.

This document *Design of Bamboo Scaffolds* presents the basic structural principles and the design method of bamboo scaffolds together with worked examples on typical use of bamboo scaffolds in building construction, and it has been presented to the following organizations for reviews and comments:

- Architectural Services Department, Government of the Hong Kong Special Administrative Region (HKSAR)
- Buildings Department, Government of the HKSAR
- Housing Department, Government of the HKSAR
- The Joint Structural Division of the Hong Kong Institution of Engineers and the Hong Kong Division of the Institution of Structural Engineers, U.K.

Contents

| | |
|---|-------|
| 1. Structural bamboo and bamboo scaffolds | 1 - 1 |
| 1.1 Introduction | 1 - 1 |
| 1.2 Bamboo scaffolds | 1 - 1 |
| 1.3 Recent research in structural bamboo | 1 - 2 |
| 1.4 Limit state design | 1 - 4 |
| 1.5 Layout of the document | 1 - 5 |
| 2. Mechanical properties of structural bamboo | 2 - 1 |
| 2.1 Introduction | 2 - 1 |
| 2.2 Experimental investigation | 2 - 1 |
| 2.3 Pilot study | 2 - 1 |
| 2.3.1 Physical properties | 2 - 2 |
| 2.3.2 Mechanical properties | 2 - 3 |
| 2.4 Systematic tests | 2 - 3 |
| 2.5 Design data and design rules | 2 - 6 |
| 2.6 Practical considerations | 2 - 7 |
| 2.7 Conclusions | 2 - 8 |
| 3. Column buckling of structural bamboo | 3 - 1 |
| 3.1 Introduction | 3 - 1 |
| 3.2 Experimental investigations | 3 - 1 |
| 3.3 Typical failure modes | 3 - 2 |
| 3.4 Test results | 3 - 2 |
| 3.5 Column buckling design | 3 - 2 |
| 3.6 Calibration of design method | 3 - 4 |
| 3.7 Conclusions | 3 - 5 |
| 4. Connections | 4 - 1 |
| 4.1 Introduction | 4 - 1 |
| 4.2 Beam-column connection tests | 4 - 1 |
| 4.3 Typical modes of failure | 4 - 2 |
| 4.4 Test results | 4 - 2 |
| 4.5 Conclusions | 4 - 2 |
| 5. Structural forms of bamboo scaffolding systems | 5 - 1 |
| 5.1 Introduction | 5 - 1 |
| 5.2 Common bamboo members in bamboo scaffolds | 5 - 1 |
| 5.3 Loading requirements | 5 - 1 |
| 5.4 Typical applications in construction | 5 - 2 |
| 5.5 Basic configuration of SLBS | 5 - 2 |
| 5.5.1 SLBS with Kao Jue | 5 - 2 |
| 5.5.2 SLBS with Mao Jue | 5 - 3 |
| 5.6 Basic configuration of DLBS | 5 - 4 |
| 5.6.1 Primary members | 5 - 4 |
| 5.6.2 Bracing members | 5 - 5 |
| 5.6.3 Supports | 5 - 5 |
| 5.7 Arrangement of lateral restraints | 5 - 5 |

| | | |
|-----|---|-------|
| 6. | Design of bamboo scaffolds with worked examples | 6 - 1 |
| 6.1 | Introduction | 6 - 1 |
| 6.2 | General design principles | 6 - 1 |
| 6.3 | Standard dimensions of Kao Jue and Mao Jue | 6 - 1 |
| 6.4 | Design of bamboo posts | 6 - 2 |
| 6.5 | Design of a bamboo transom and a bamboo ledger | 6 - 2 |
| 6.6 | Design of a SLBS | 6 - 2 |
| 6.7 | Design of a DLBS | 6 - 3 |

| | | |
|------------|--|-------|
| References | | R - 1 |
|------------|--|-------|

Appendix A

| | | |
|--------------|---|-------|
| Appendix A.1 | Mechanical properties of various bamboo species - compression | A - 1 |
| Appendix A.2 | Mechanical properties of various bamboo species - bending | A - 2 |
| Appendix A.3 | Mechanical properties of various bamboo species - shear | A - 3 |

Figures

| | | |
|-------------|---|--------|
| Figure 1.1 | Typical bamboo scaffold – Double Layered Bamboo Scaffold (DLBS) | 1 - 5 |
| Figure 1.2 | Typical bamboo scaffold – Single Layered Bamboo Scaffold (DLBS) | 1 - 6 |
| Figure 1.3 | Typical configuration of a double layered bamboo scaffold | 1 - 7 |
| Figure 1.4 | A close-up on the ledger-post connection | 1 - 7 |
| Figure 1.5 | Detail of a putlog attaching the post of the outer layer in a DLBS | 1 - 8 |
| | | |
| Figure 2.1 | Compression test | 2 - 9 |
| Figure 2.2 | Variation of physical properties along length of bamboo culms | 2 - 10 |
| Figure 2.3 | Variation of mechanical properties along length of bamboo culms | 2 - 11 |
| Figure 2.4 | Bending test | 2 - 12 |
| Figure 2.5 | Variation of mechanical properties of Kao Jue against moisture content | 2 - 13 |
| Figure 2.6 | Variation of mechanical properties of Mao Jue against moisture content | 2 - 14 |
| Figure 2.7 | Variation of mechanical properties of Kao Jue against moisture content | 2 - 15 |
| Figure 2.8 | Variation of mechanical properties of Mao Jue against moisture content | 2 - 16 |
| Figure 2.9 | Variation of model factors of Kao Jue against moisture content | 2 - 17 |
| Figure 2.10 | Variation of model factors of Mao Jue against moisture content | 2 - 18 |
| Figure 2.11 | Design data of the dimensions of Kao Jue and Mao Jue | 2 - 19 |
| | | |
| Figure 3.1 | General setup of column buckling tests | 3 - 6 |
| Figure 3.2 | Failure modes of bamboo column | 3 - 7 |
| Figure 3.3a | Typical load deflection curves of column buckling test (Kao Jue) | 3 - 8 |
| Figure 3.3b | Typical load deflection curves of column buckling test (Mao Jue) | 3 - 8 |
| Figure 3.4 | Column buckling analysis for Kao Jue and Mao Jue | 3 - 9 |
| Figure 3.5 | Model factors for column buckling design | 3 - 10 |
| | | |
| Figure 4.1 | Typical setup of beam-column connection tests | 4 - 3 |
| Figure 4.2 | Typical load deflection curves for ledger-post connections using bamboo strips | 4 - 4 |
| Figure 4.3 | Typical load deflection curves for ledger-post connections using plastic strips | 4 - 4 |
| Figure 4.4 | Slipping between member | 4 - 5 |
| Figure 4.5 | Strip splitting | 4 - 5 |
| | | |
| Figure 5.1a | Typical configuration of SLBS and DLBS | 5 - 8 |
| Figure 5.1b | Typical configuration of SLBS and DLBS | 5 - 8 |
| Figure 5.1c | Typical configuration of SLBS and DLBS | 5 - 9 |
| Figure 5.2a | Results of SLBS with Kao Jue at H equal to 2 h | 5 - 10 |
| Figure 5.2b | Results of SLBS with Kao Jue at H equal to 2.667 h | 5 - 11 |
| Figure 5.2c | Results of SLBS with Kao Jue at H equal to 3 h | 5 - 12 |
| Figure 5.3a | Results of SLBS with Mao Jue at H equal to 2 h | 5 - 13 |
| Figure 5.3b | Results of SLBS with Mao Jue at H equal to 2.667 h | 5 - 14 |
| Figure 5.3c | Results of SLBS with Mao Jue at H equal to 3 h | 5 - 15 |
| Figure 5.4a | Results of DLBS | 5 - 16 |
| Figure 5.4b | Results of DLBS | 5 - 17 |

Tables

| | | |
|------------|--|--------|
| Table 2.1a | Summary of physical and mechanical properties of <i>Bambusa Pervariabilis</i> (Kao Jue) | 2 - 20 |
| Table 2.1b | Summary of physical and mechanical properties of <i>Phyllostachys Pubescens</i> (Mao Jue) | 2 - 20 |
| Table 2.2 | Proposed mechanical properties for <i>Bambusa Pervariabilis</i> (Kao Jue) and <i>Phyllostachys Pubescens</i> (Mao Jue) | 2 - 21 |
| Table 3.1 | Details of test series for Kao Jue | 3 - 11 |
| Table 3.2 | Details of test series for Mao Jue | 3 - 12 |
| Table 3.3 | Non-prismatic parameter α_c for column buckling of Mao Jue | 3 - 13 |
| Table 3.4 | Strength reduction factor, $\bar{\psi}_c$ | 3 - 14 |
| Table 4.1 | Test program for beam-column connections using bamboo strips | 4 - 6 |
| Table 4.2 | Test program for beam-column connections using plastic strips | 4 - 7 |
| Table 4.3 | Summary of structural performance of connections (without nodes) | 4 - 8 |
| Table 4.4 | Summary of structural performance of connections (with nodes) | 4 - 8 |
| Table 5.1 | General load requirements for bamboo scaffolds | 5 - 18 |
| Table 5.2 | Material specification for SLBS and DLBS | 5 - 19 |
| Table 5.3 | Load resistances and effective length coefficients of SLBS and DLBS derived from NIDA | 5 - 20 |

Worked Examples

| | | |
|-------------------|--|--------|
| Worked Example 1: | Design of bamboo post using Kao Jue | 6 - 4 |
| Worked Example 2: | Design of bamboo post using Mao Jue | 6 - 5 |
| Worked Example 3: | Design of a bamboo transom and a bamboo ledger using Kao Jue | 6 - 6 |
| Worked Example 4: | Design of a short span SLBS using Kao Jue | 6 - 7 |
| Worked Example 5: | Design of a long span SLBS using Mao Jue | 6 - 8 |
| Worked Example 6: | Design of a DLBS | 6 - 10 |

1. Structural bamboo and bamboo scaffolds

1.1 Introduction

Timber is regarded as a good natural structural material, and probably, one of the oldest known materials used in construction. A number of design recommendations^[1-3] on timber are available, and currently, most of them employ permissible stress design. In a modern structural timber code^[4], ultimate limit state design philosophy is adopted and structural adequacy is assessed with characteristic values of both loading and resistance using appropriate partial safety factors. Among many physical properties that affect the strength characteristics of timber, moisture content, density, slope of grain and defects are regarded as the most important ones.

Bamboo is another natural structural material, and there are over 1500 different botanical species of bamboo in the world. Many of them have been used traditionally as structural members in low-rise houses, short span foot bridges, long span roofs and construction platforms in countries with plentiful bamboo resources. Studies have shown bamboo to be an ideal and safe structural material for many construction applications. In general, it is believed that the mechanical properties of bamboo is likely to be at least similar, if not superior, to those of timber. Furthermore, as bamboo grows very fast and usually takes three to six years to harvest, depending on the species and the plantation, there is a growing global interest in developing bamboo as a substitute of timber in construction. The effective use of structural bamboo will mitigate the pressures on the ever-shrinking natural forests in developing countries, and thus, facilitate the conservation of the global environment. However, a major constraint to the development of bamboo as a modern construction material is the lack of design standards for structural bamboo.

1.2 Bamboo scaffolds

Bamboo scaffolds have been used in building construction in China for over a few thousand years. It is believed among Chinese that the first bamboo scaffold was built some 5000 years ago while the basic framing systems and the erection methods were established through practice about two thousand years ago. Bamboo scaffolds provide temporary access, working platforms for construction workers and supervisory staff, and also prevents construction debris from falling onto passers-by. In Hong Kong and other parts of the Southern China, bamboo scaffolds are ones of the few traditional building systems which survive by self-improvement through practical experiences of scaffolding practitioners over generations. Nowadays, in spite of open competition with many metal scaffolding systems imported all over the world, bamboo scaffolds remain to be one of the most preferred systems for access in building construction in Hong Kong and the neighbouring areas.

Typical usage of bamboo scaffolds in building construction include:

- Single Layered Bamboo Scaffolds (SLBS) for light duty work such as exterior decoration. It is highly adaptable to site conditions with both easy erection and dismantling.

- Double Layered Bamboo Scaffolds (DLBS) with working platform for heavy duty work such as masonry work, installation of curtain walls. It provides safe working platforms for complicated operations to be carried out at heights.

Figures 1.1 and 1.2 illustrate some of the typical applications of bamboo scaffolds in Hong Kong. Owing to their high adaptability and low construction cost, bamboo scaffolds can be constructed in any layout to follow various irregular architectural features of a building within a comparatively short period of time. Besides widely erected on construction sites, they are also used in signage erection, decoration work, demolition work and civil work. Typical usage of bamboo scaffolds is widely reported to the community of structural engineers^[5]. Moreover, industrial guides on safety of bamboo scaffolds are also available^[6-8].

Figure 1.3 illustrates the typical configuration of a double layered bamboo scaffold, showing the arrangement of posts, ledgers, transoms and diagonals. A close-up on the ledger-post connection is presented in Figure 1.4 while a putlog attaching the post of the outer layer is shown in Figure 1.5.

The major advantages of bamboo as a scaffolding material are high strength-to-weight ratio, simple erection, and easy adaptability to building forms and site conditions. Bamboo culms used for both the standards (vertical members) and the ledgers (horizontal members) in scaffolds range from 40 to 100 mm in diameters and 6 to 8 m in length, and they are light enough for one person to easily handle a single culm at a time. Due to the ease of handling, bamboo scaffolds are easily and efficiently erected and dismantled; compared to steel scaffolds, where installation and dismantling take the same amount of time, bamboo scaffolds can be dismantled in a tenth of the time it takes to install. Machinery, power-driven tools and tightening equipment are not necessary, as simple hand tools and nylon or wire ties suffice to erect the bamboo scaffolds. The typical height of bamboo scaffolds is 15 m and the installation of steel bracket supports at regular intervals allow full coverage of building height up to 100 m (or 30 storeys).

Bamboo scaffolds are traditionally erected by specialized scaffolding practitioners, and thus the safety and effectiveness of the bamboo scaffolds depend primarily on the individual skills of the practitioners. This knowledge is passed on younger workers through an apprentice system, mostly through on-the-job learning. With the natural variations and lack of quality control of bamboo culms, which varies with species, maturity, moisture content, can affect the load bearing properties of culms, and also the strength of the connections.

1.3 Recent research in structural bamboo

Structural bamboo have been used traditionally in China, Phipplines, India, and Latin America for many hundred of years, but little research was reported in the past. Recent scientific investigations on bamboo as a construction material were reported by Au, Ginsburg, Poon and Shin in Hong Kong in 1978^[9], and also by Janssen in Holland in 1981^[10]. A large amount of data of the mechanical properties for various bamboo species all over the world were reported in 1991^[11]; however, only typical ranges of values were provided. More recently, a study^[12] was reported where bamboo was classified as a smart natural composite material with optimized distribution of fibers and matrices, both across cross sections and along member lengths, in resisting environmental loads in nature.

A series of experimental studies on structural bamboo were reported by Arce-Villalobos in 1993^[13] and practical connection details for bamboo trusses and frames were also proposed and tested. Moreover, a recent study^[14] on the traditional design and construction of bamboo in low-rise housing in Latin America is also available, and innovative applications of bamboo^[15] in building construction in India is also reported.

As part of a theoretical investigation on structural stability of slender structures, an numerical investigation using advanced finite element analysis of one element per member^[16] was carried in Hong Kong to assess the load carrying capacities of bamboo scaffolds. Moreover, a full-scale bamboo scaffold was built in a construction site and tested to failure^[17] in order to provide data for calibration of the finite element model. Due to the slenderness of bamboo culms, it was found that non-linear analysis was often required to predict the buckling behaviour of bamboo scaffolds accurately.

In 1999, a research and development project titled 'Bamboo Scaffolds in Building Construction' was undertaken at the Research Center For Advanced Technology in Structural Engineering (*RCATISE*) of the Hong Kong Polytechnic University with the support of the International Network of Bamboo and Rattan (*INBAR*). The major objective of the project is to promote the effective use of bamboo scaffolding in building construction through advancement and dissemination of structural bamboo technology, and the major tasks and deliverables derived from the project^[18] are described as follows:

Task 1 Dissemination of Established Bamboo Scaffolding Technology

To promote the effective use of bamboo scaffolding in building construction through dissemination of technical information. Both the established knowledge and the proven practice of bamboo scaffolding in Hong Kong have been formalized and documented:

Task 1A Design Guide entitled '*Design of Bamboo Scaffolds*' covering material requirements, typical usage, structural principles and safety requirements for structural engineers.

Task 1B Erection Manual entitled '*Erection of Bamboo Scaffolds*'^[19] covering material selection, typical configurations with details, and erection procedures for scaffolding practitioners.

Task 2 Development of Engineered Bamboo Scaffolding Systems

Task 2A To develop engineered bamboo scaffolding for typical applications with improved structural forms through advanced analysis and design.

Task 2B To establish connection resistances of conventional and engineered connections^[20] for practical design of bamboo scaffolds.

Task 3 General Technical Information of Structural Bamboo

In order to facilitate wide engineering applications of bamboo, a document titled '*Engineering and Mechanical Properties of Structural Bamboo*'^[21] is compiled to provide general technical information on bamboo as a constructional material.

For easy reference, key findings of the research and development project directly related to the design of bamboo scaffolds are presented as follows:

- As bamboo culms are natural non-homogenous organic materials, large variations of physical properties along the length of bamboo members are apparent: external and internal diameters, dry density and moisture content. In Hong Kong, two bamboo species, namely *Bambusa Pervariabilis* (or Kao Jue) and *Phyllostachys Pubescens* (or Mao Jue) are commonly used in access scaffolds. An experimental investigation was thus carried out by Chung and Yu^[22] to examine the variation of compressive strength against various physical properties along the length of bamboo culms for both Kao Jue and Mao Jue. Moreover, systematic test series with a large number of compression and bending tests were also executed^[22-24] to establish characteristic values of both the strengths and the Young's moduli of each bamboo species for limit state structural design.
- Due to the slenderness of bamboo members, column buckling is always critical in bamboo scaffolds, and thus, an extensive and systematic experimental testing on column buckling tests for both Kao Jue and Mao Jue over a wide range of practical member lengths were executed to examine their column buckling behaviour^[25]. In accordance with existing structural design philosophy on column buckling for both steel and timber structures, a design method based on modified slenderness was proposed for general design of both Kao Jue and Mao Jue after careful calibration against test data. The Perry-Robertson interaction formula was adopted to incorporate the effect of initial imperfection during the evaluation of the compressive buckling strength of bamboo columns. It should be noted that any significant variation on the physical and the mechanical properties along the member length of bamboo columns should be incorporated in assessing their axial buckling resistances.
- After establishing the physical and the mechanical properties of structural bamboo and the design rules against axial buckling of bamboo columns, it is necessary to investigate the structural stability of typical bamboo scaffolding systems. A total of four full-scale bamboo scaffolds were built and tested to failure in order to examine the structural behaviour of typical bamboo scaffolding systems^[26] commonly used in Hong Kong. The measured load carrying capacities of these bamboo scaffolds^[27,28] were compared with practical load requirements, and then assessed with the proposed design method for bamboo column buckling.

1.4 Limit state design

Modern codes are presented in terms of limit state design in which partial factors of safety are applied to the loads and also to the material properties. The loads to be used in design are determined from the working loads multiplied by factors of 1.6 for imposed loads and 1.4 for dead loads (including self weight) as specified in British codes of structural concrete^[29], steel^[30] and timber^[4]. These so-called factored loads are used to determine the moments and forces in the members, which are then compared to the ultimate load capacity of the structures, as determined by modes of failure, such as section capacity, buckling resistance, connection failure. The methods are not applicable to working load or permissible stress design, although a global factor of safety of 1.6 may be used when determining maximum working loads that the structure can support. Checks on deflection are made for working loads in order to ensure adequate performance in service.

It should be noted that an international design code for structural bamboo and a INBAR standard on the determination of physical and mechanical properties of bamboo are recently available^[31,32]. These two documents are generally considered to be the definitive references on the respective subjects.

1.5 Layout of the document

Chapter 2 presents an experimental investigation on the mechanical properties of two bamboo species, namely *Bambusa Pervariabilis* (or Kao Jue) and *Phyllostachys Pubescens* (or Mao Jue), which are commonly used in access scaffoldings in the South East Asia, in particular, in Hong Kong and the Southern China. Based on systematic compression and bending testing on a large number of test specimens, characteristic values of both the strengths and the Young's moduli of each bamboo species for limit state structural design are provided for practical design.

In general, column buckling is considered to be one of the critical modes of failure in bamboo scaffolds, leading to overall structural collapse. Chapter 3 presents the design development of a limit state design method against column buckling of structural bamboo. A total of 72 column buckling tests for both Kao Jue and Mao Jue are executed to provide test data, and a design method against column buckling for both Kao Jue and Mao Jue is proposed for general design after careful calibration.

Chapter 4 presents an experimental investigation on the connection resistances in bamboo scaffolds where the connections are formed using either bamboo strips or plastic strips. After statistical analysis, the characteristic connection resistances of the beam-column connections and the column splices with Kao Jue and Mao Jue are presented for practical design.

Chapter 5 presents the basic configurations of typical bamboo scaffolds using both Kao Jue and Mao Jue, namely, the Single Layered Bamboo Scaffolds (SLBS) and the Double Layered Bamboo Scaffolds (DLBS). The results of a parametric study on the structural behaviour of bamboo scaffolds with different practical arrangements of lateral restraints are presented, and recommendations on the effective length coefficients for posts in both SLBS and DLBS with different practical arrangements of lateral restraints are also provided.

Chapter 6 presents the general design principles of bamboo scaffolds. The design procedures of a number of typical structural bamboo members and scaffolding systems are fully presented through worked examples. Moreover, the design of both SLBS and DLBS are also fully presented with proper consideration of various arrangements of lateral restraints for practical applications.



Figure 1.1 Typical bamboo scaffold – Double Layered Bamboo Scaffold (DLBS)



Figure 1.2 Typical bamboo scaffold – Single Layered Bamboo Scaffold (SLBS)



Figure 1.3 Typical configuration of a double layered bamboo scaffold



Figure 1.4 A close-up on the ledger-post connection



Figure 1.5 Detail of a putlog attaching the post of the outer layer in a DLBS

2. Mechanical properties of structural bamboo

2.1 Introduction

This Chapter presents an investigation on the mechanical properties of two bamboo species, namely *Bambusa Pervariabilis* (or Kao Jue) and *Phyllostachys Pubescens* (or Mao Jue), which are commonly used in access scaffolds in the South East Asia, in particular, in Hong Kong and the Southern China. A pilot study was carried out to examine the variation of compressive strength against various physical properties along the length of bamboo culms for both bamboo species. Moreover, systematic test series with a large number of compression and bending tests were executed to establish characteristic values of both the strengths and the Young's moduli of each bamboo species for limit state structural design. It is shown that both Kao Jue and Mao Jue are good constructional materials with excellent mechanical properties against compression and bending. With a suitable choice of partial safety factors, structural engineers are able to design bamboo structures at a known level of confidence against failure.

2.2 Experimental investigation

As natural non-homogenous organic materials, large variations of physical properties along the length of bamboo culms are apparent: external and internal diameters, dry density and moisture content. While engineers also expect variations in the mechanical properties of bamboo, they tend to accept that the mechanical properties of bamboo are likely to be more consistent than those of concrete, probably similar to timber. An experimental investigation was carried out to establish the mechanical properties of two bamboo species, namely, *Bambusa Pervariabilis* (or Kao Jue) and *Phyllostachys Pubescens* (or Mao Jue), which are commonly used in Hong Kong and the Southern China in bamboo scaffolds.

The experimental investigation may be divided into the following parts:

- Pilot study
A pilot study is first carried out to examine the variation of compressive strength against a number of physical properties along the length of bamboo culms of both bamboo species.
- Systematic tests
A number of test series are then carried out to generate test data on the compressive and the bending strengths together with associated Young's moduli of both bamboo species. In each test series, a large number of destructive tests on bamboo culms are carried out over a wide range of physical properties against natural occurrence. Statistical analysis on the test data is then performed to establish the characteristic mechanical properties of both bamboo species for structural design.

2.3 Pilot study

The primary physical properties of bamboo culms are:

- External diameter, D ,
- Wall thickness, t , (and cross-sectional area, A)
- Dry density, ρ , and
- Moisture content, $m.c.$

Some of these physical parameters vary significantly along the length of bamboo culms, depending on the species. For structural application, it is important to establish the mechanical properties of the bamboo culms, and also any co-relation between their physical and mechanical properties.

A test series was carried out to examine the variation of the compressive strengths of both Kao Jue and Mao Jue along the length of bamboo culms against all the primary physical properties. For each species, three dry bamboo culms were tested, and all of them were mature with an age of at least three years old with no visual defect. The test specimens were prepared as follows:

- A length of 750 mm from both the top and the bottom ends of each bamboo culm was discarded.
- A number of test specimens were cut out from the bamboo culms at regular intervals, each marked with a label indicating its position from the bottom of the bamboo culm.
- The length of each test specimen was about twice the external diameter of the bamboo culms, but not larger than 150 mm.

All the physical properties of the test specimens were measured before and after the compression tests as appropriate.

Figure 2.1 illustrates the general set-up of the compression tests, and both the applied loads and the axial shortening of the test specimens were measured during the tests. Two failure modes, namely *End bearing* and *Splitting*, were identified, as shown in Figure 2.1. It was found that most specimens failed in *End Bearing*, especially in those specimens with high moisture contents. As the moisture content decreased, cracks along fibers were often induced and caused *Splitting*. Typical load deflection curves of test specimens associated with both failure modes are also presented in Figure 2.1.

After data analysis, Figure 2.2 presents the variations of the physical properties along the length of the bamboo culms for both Kao Jue and Mao Jue. The variations of the failure loads, the ultimate compressive strengths and also the Young's modulus against compression are presented in Figure 2.3.

2.3.1 Physical properties

- Kao Jue

In general, the physical properties of all three culms are found to be very similar among each other. It is shown that while the external diameter is fair uniform over the length of the bamboo culms with a typical value of 45 mm, the wall thickness varies from 8 mm at the bottom to 4 mm at the top of the culm. Consequently, the average cross-sectional area is 750 mm^2 with a variation of 250 mm^2 along the whole member length. However, both the averaged dry density and the moisture content are fairly uniform with a value of 700 kg/m^3 and 12.5% respectively along the whole member length.

- Mao Jue

On the contrary to Kao Jue, the physical properties of the three culms are found to be significantly different among each other. From the bottom to the top of the culms, the external diameter is typically reduced from 80 mm to 50 mm. Moreover, the wall thickness varies from 10 mm at the bottom to 6 mm at the top of the culms. Consequently, the average cross-sectional area is found to be 1750 mm² with a large variation of 1000 mm² along the whole member length. However, it is important to note that the dry density is somehow uniform with an averaged value of 700 kg/m³ and a variation of 100 kg/m³ along the whole member length. Large variation in the moisture content along the member length is apparent, ranging from 50% at the bottom to 15% at the top of the culms.

2.3.2 Mechanical properties

- Kao Jue

The compression capacity is found to be at its maximum of about 60 kN at the bottom of the culm which is reduced steadily to about 30 kN at the top. After dividing with the cross-sectional areas, the compressive strength is found to vary from 60 to 80 N/mm² along the whole culm length. However, large variation in the Young's modulus against compression is apparent, scattering between 4 kN/mm² and 12 kN/mm² along the whole culm length.

- Mao Jue

Contrary to the physical properties, the mechanical properties of the three culms are found to be broadly similar. From the bottom to the top of the culms, the compression capacity is reduced steadily from 100 kN at the bottom of the culms to 50 kN at the top. After dividing with the cross-sectional areas, the compressive strength is found to be 50 N/mm² at the bottom of the culms which increases steadily to 70 N/mm² at the top. The Young's modulus against compression is found to vary steadily from 5 kN/mm² to 10 kN/mm² from the bottom to the top of the culms.

Consequently, it is shown that despite of the large variations in external diameter, wall thickness and dry density, representative values of mechanical properties may be obtained from systemic testing for both Kao Jue and Mao Jue. Among all the physical properties, it is found that moisture content is the most important one in defining the mechanical properties of the bamboo.

2.4 Systematic tests

In order to generate safe design data on the compressive and the bending strengths together with associated Young's moduli of each bamboo species, a set of systematic test series, or a qualification test programme, was executed. In each test programme, a large number of destructive tests on bamboo culms under compression and bending were carried out over a wide range of moisture contents as follows:

a) Normal tests

The tests aimed to measure the compressive and the bending strengths of the test specimens in normal supply condition, i.e. *Green (G0)* and *Green + 3 months (G3)*. For each member position, six specimens were tested.

b) Wet tests

The tests aimed to measure the compressive and the bending strengths of the test specimens with high moisture contents. For each member position, two specimens were immersed under water over different time periods.

c) Dry tests

The tests aimed to measure the compressive and the bending strengths of the test specimens with low moisture contents. For each member position, two specimens were dried in oven at 105°C over different time periods.

The designation system for the test specimens is defined as follows:

| Normal Tests - <i>G0 / G3</i> | Wet Tests - <i>W</i> | Dry Tests - <i>D</i> |
|--|--|--|
| $\begin{Bmatrix} A \\ B \\ C \end{Bmatrix} X \{1, 2, 3, 4, 5, 6\}$ | $\begin{Bmatrix} A \\ B \\ C \end{Bmatrix} W \{a, b, c, d, e, f, g, h, i\} \begin{Bmatrix} 1 \\ 2 \end{Bmatrix}$ | $\begin{Bmatrix} A \\ B \\ C \end{Bmatrix} D \{a, b, c, d, e, f, g, h, i\} \begin{Bmatrix} 1 \\ 2 \end{Bmatrix}$ |
| No. of tests = 3 x 6 x 2 = 36 | No. of tests = 3 x 9 x 2 = 54 | No. of tests = 3 x 9 x 2 = 54 |

where the time periods *a* to *i* are defined as follows:

| <i>a</i> | <i>b</i> | <i>c</i> | <i>d</i> | <i>e</i> | <i>f</i> | <i>g</i> | <i>h</i> | <i>i</i> |
|----------|----------|----------|----------|----------|----------|----------|----------|----------|
| 1 hr | 2 hrs | 4 hrs | 8 hrs | 12 hrs | 1 day | 2 days | 3 days | 7 days |

In general, the test specimens were selected and prepared as follows:

- All bamboo culms were about 6 metres in length and of 3 to 6 years of age. They were air dry for at least 3 months before testing.
- A length of 750 mm from both the top and the bottom ends of the bamboo culms was discarded.
- Three specimens were cut out from the top, the middle and the bottom positions of the culm and marked with the letters *A*, *B*, and *C* respectively.
- The length of each specimen was about 1500 mm with acceptable out-of-straightness under visual inspection. The external diameters at the top and the bottom ends did not differ by more than 25 mm.

Two tests were carried out in the qualification test programmes as follows:

- Compression Tests

After each bending test, two compression test specimens were taken from the bending test specimen. The height of the compression test specimens was at least two times the diameter of the bamboo culm and larger than 75 mm. The specimens were tested under axial compression until failure, similar to those compression tests in the Pilot study.

Two failure modes, namely *End bearing* and *Splitting*, were identified, as shown in Figure 2.1. It was found that most specimens failed in *End Bearing*, especially in those specimens with high moisture contents. As the moisture content decreased, cracks along fibers were often induced and caused *Splitting*. Refer to Figure 2.1 for typical load

deflection curves of test specimens associated with both failure modes; they are similar to those obtained in the Pilot study.

- **Bending Tests**

Each bending test specimen was supported over a clear span of 1200 mm. The specimens were tested under single point load at mid-span until failure as shown in Figure 2.4.

Two failure modes, namely, *Splitting* and *Local crushing* were identified, as shown in Figure 2.4. It was found that most specimens failed in *Splitting*, especially for those specimens with low moisture contents. For test specimens with high moisture contents, the specimens collapsed under combined bending and patch load, leading to *Local crushing*. Typical load deflection curves of test specimens associated with both failure modes are also presented in Figure 2.4.

A number of qualification test programmes for both Kao Jue and Mao Jue have been executed for different batches of samples, and statistical analysis on all the test data were carried out to establish the characteristic mechanical properties of the bamboo species for structural design. Table 2.1 summarizes the ranges of the measured mechanical properties obtained from the qualification test programmes. Moreover, the ranges of the physical properties covered in all the tests are also presented.

Based on a total of 364 compression tests and 91 bending tests, the variations of the compressive strength, f_c , and the bending strength, f_b , of Kao Jue against moisture contents are illustrated in Figure 2.5 respectively. Similarly, based on a total of 213 compression tests and 128 bending tests, the variations of the compressive strength, f_c , and the bending strength, f_b , of Mao Jue against moisture contents are illustrated in Figure 2.6 respectively. The Young's moduli under compression and bending for both Kao Jue and Mao Jue are plotted in Figures 2.7 and 2.8 respectively. It should be noted that

- Kao Jue

Both the compressive and the bending strengths are over 75 N/mm² in dry condition, i.e. *m.c.* < 5 %. In wet condition, i.e. *m.c.* > 20 %, both strengths are reduced roughly by half to 35 N/mm². The Young's moduli against compression and bending are 6.4 kN/mm² and 15.0 kN/mm² respectively in dry condition, and they are reduced roughly by half in wet condition.

- Mao Jue

The compressive strength is over 115 N/mm² in dry condition, i.e. *m.c.* < 5 %. However, in wet condition, i.e. *m.c.* > 30 %, the strength is reduced roughly to one third of its original value, i.e. to 40 N/mm². The bending strength may be taken at 50 N/mm², irrespective to the moisture content. The Young's moduli against compression and bending are 5.9 kN/mm² and 9.0 kN/mm² respectively in dry condition, and they are roughly reduced by one third to 4.5 kN/mm² and 6.0 kN/mm² respectively in wet condition.

2.5 Design data and design rules

In order to provide simple and effective design data, statistical analysis is carried out over three different ranges of moisture contents (*m.c.*) as shown in the pilot study:

Kao Jue

(a) *m.c.* < 5 %, (b) *m.c.* = 5 ~ 20 %, and (c) *m.c.* > 20 %.

Mao Jue

(a) *m.c.* < 5 % (b) *m.c.* = 5 ~ 30 %, and (c) *m.c.* > 30 %.

Table 2.2 summarizes the proposed characteristic compression and bending strengths together with associated Young's moduli at 95 % probability. The material partial safety factor for bamboo, γ_m , is proposed to be 1.5. It should be noted that the characteristic values of the mechanical properties of both Kao Jue and Mao Jue are shown to be superior to common structural timber, and probably also to concrete.

Simple design rules for both Kao Jue and Mao Jue against compression and bending are proposed as follows:

- Compression : $F_{design} = f_{c,d} \times A_m$
- Bending : $M_{design} = f_{b,d} \times Z_m$

where

A_m, Z_m are measured cross-sectional area and section modulus respectively,
 F_{design}, M_{design} are design compressive force and moment capacity respectively,
 $f_{b,k}, f_{b,d}$ are characteristic and design bending strengths respectively,

$E_{c,k}, E_{c,d}$ are characteristic and design Young's moduli under compression respectively,

$E_{b,k}, E_{b,d}$ are characteristic and design Young's moduli under bending respectively,

γ_m is a partial safety factor for material strength.

$f_{c,k}, f_{c,d}$ are characteristic and design compressive strengths respectively,

In order to assess the structural adequacy of the design rules, model factors ψ are established which are defined as follows:

- Compression : $\psi_c = \frac{F_{test}}{F_{design}}$
- Bending : $\psi_b = \frac{M_{test}}{M_{design}}$

where

ψ_c, ψ_b are model factors for compression test and bending test respectively, and
 F_{test}, M_{test} are measured compressive force and moment capacity respectively.

For the qualification test programmes, Figures 2.9 and 2.10 plot the model factors of the design rules for compression and bending for both Kao Jue and Mao Jue against moisture contents respectively. The average model factors for compression are found to be 1.98 and

2.04 for Kao Jue and Mao Jue respectively while the average model factors for bending are found to be 2.18 and 2.40 for Kao Jue and Mao Jue respectively. Consequently, the proposed design rules are shown to be adequate over a wide range of moisture contents.

It should also be noted that the model factors of the design rules for compression against position along bamboo culms are presented in Figure 2.3 for both Kao Jue and Mao Jue. The average model factors for compression are found to be 1.83 and 2.13 for Kao Jue and Mao Jue respectively. Consequently, the proposed design rules are shown to be adequate along the length of bamboo culms.

2.6 Practical considerations

For structural design of bamboo scaffolds in practice, the following should be noted:

a) Design data of the dimensions of Kao Jue and Mao Jue

In general, the following dimensions of both Kao Jue and Mao Jue should be adapted in structural design:

- For Kao Jue, the external and the internal diameters are 40 and 30 mm respectively and they are considered to be constant along the length of the bamboo; the wall thickness is 5 mm.
- For Mao Jue, the external and the internal diameters at the top cross-section are 60 and 48 mm respectively and they are considered to increase linearly down to the bottom cross-section to 90 and 72 mm respectively over a length of 6 m. The wall thickness increases linearly from 6 mm at the top cross-section to 9 mm at the bottom cross-section.

The dimensions of Kao Jue and Mao Jue are illustrated in Figure 2.11.

b) Mechanical properties

The mechanical properties of both Kao Jue and Mao Jue are presented in Table 2.2 with appropriate characteristic values for design over practical ranges of moisture contents. Typical mechanical properties of various bamboo species are presented in Appendix A for information.

It should be noted that for structural bamboo in bamboo scaffolds, shear force is comparatively less critical when compared with bending and column buckling. Nevertheless, design guidance on the shear strength of both Kao Jue and Mao Jue are provided in a simple and conservative manner. As shown in Appendix A, the shear strengths of various bamboo species are found to range typically from 6 to 15 N/mm², and they are broadly proportional to the compressive strengths of the bamboo species. Consequently, it is recommended that the shear strength may be conservatively estimated as 25 % of the compressive strength for all bamboo species for practical design.

c) Moisture content

In general, the moisture contents at normal supply condition, i.e. air dry for three months after harvest, or *G3*, may be used to determine the design strengths of exposed bamboo scaffolds in dry seasons. Typical moisture contents for both Kao Jue and Mao Jue at *G3* are found to be 12.5 % and 20 % respectively. For exposed bamboo scaffolds with an intended life of usage over wet reasons, a conservative approach should be taken and all the mechanical properties should be evaluated at high moisture contents.

d) Partial safety factors

For ultimate limit state design, a material factor of 1.5 should be used in general. However, the material factor may be reduced to 1.25 for those bamboo culms supplied under proper quality control as appropriate. Moreover, it is recommended that the partial safe factor for construction load should be 2.0 in general. However, for construction sites with proper management and supervision on bamboo scaffolds, the load factor may be reduced to 1.6 as appropriate. With a suitable choice of partial safety factors, structural engineers are thus able to design bamboo scaffolds at a known level of confidence against failure.

e) Column buckling

Due to the slenderness of the bamboo culms, column buckling is always critical in bamboo scaffolds, especially in compression members with few restraints. Furthermore, it is also important to incorporate the non-uniformity of flexural rigidity along the culm length as both the cross-sectional area and the Young's modulus vary significantly from the top to the bottom of a culm.

f) Connections

In general, all connections in bamboo scaffolds are made up with plastic strips by hands, and they are considered as simple connections in design. Obviously, both the strength and the stiffness of the connections depend primarily on the workmanship of scaffolding practitioners. It is important to ensure that all the connections in bamboo scaffolds are strong and reliable in both dry and wet conditions over prolonged periods.

2.7 Conclusions

A pilot study on two bamboo species was carried out to examine the variation of compressive strengths along the culm lengths. It was found that despite of large variations in external diameter, wall thickness and dry density, representative values of mechanical properties were obtained through systemic testing. Among all the physical properties, moisture content is found to be the most important one in defining the mechanical properties of bamboo. Moreover, a number of qualification test programmes were also executed to generate safe engineering data on the mechanical properties of bamboo for structural design. It was established that the characteristic values of the mechanical properties of the bamboo were often superior to common structural timber, and probably also to concrete. In order to qualify any bamboo species as a structural bamboo, qualification test programmes should be conducted to establish its mechanical properties. For both Kao Jue and Mao Jue, design data and simple design rules for compression and bending in typical applications are presented, and appropriate partial safety factors are also suggested.



a) General test set-up

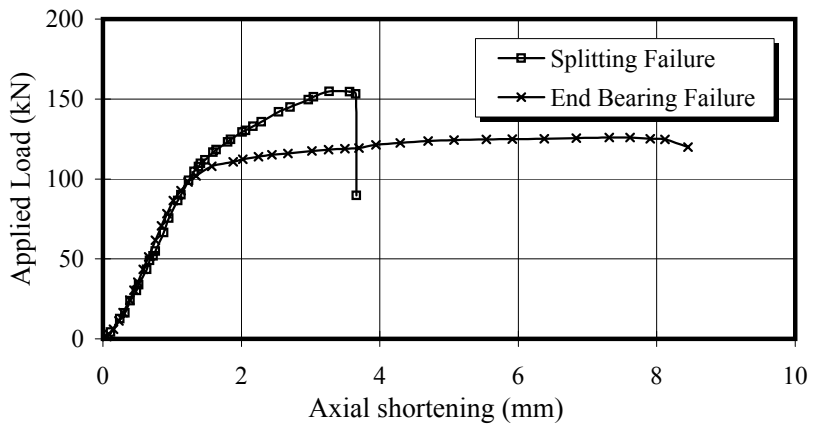

b) Load deflection curves



c) Typical failure mode - End bearing



d) Typical failure mode - Splitting

Figure 2.1 Compression test

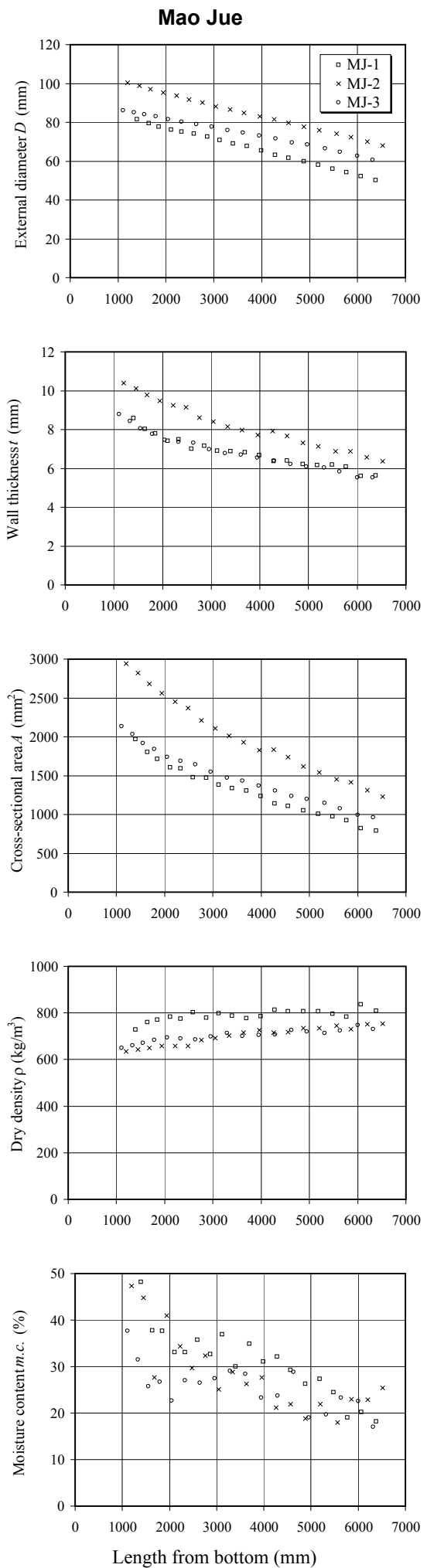
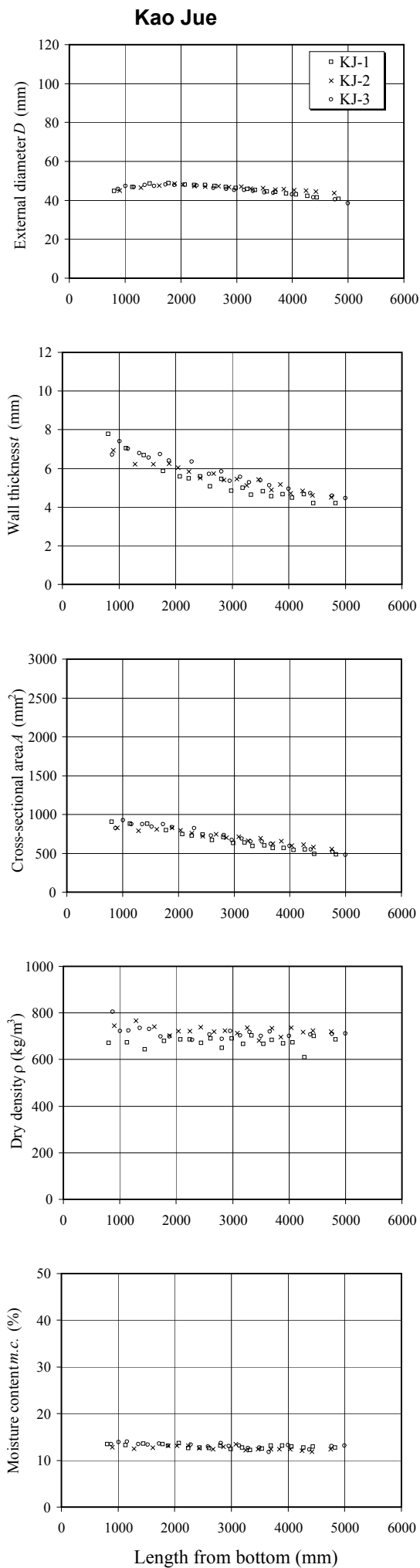

Figure 2.2 Variation of physical properties along length of bamboo culms

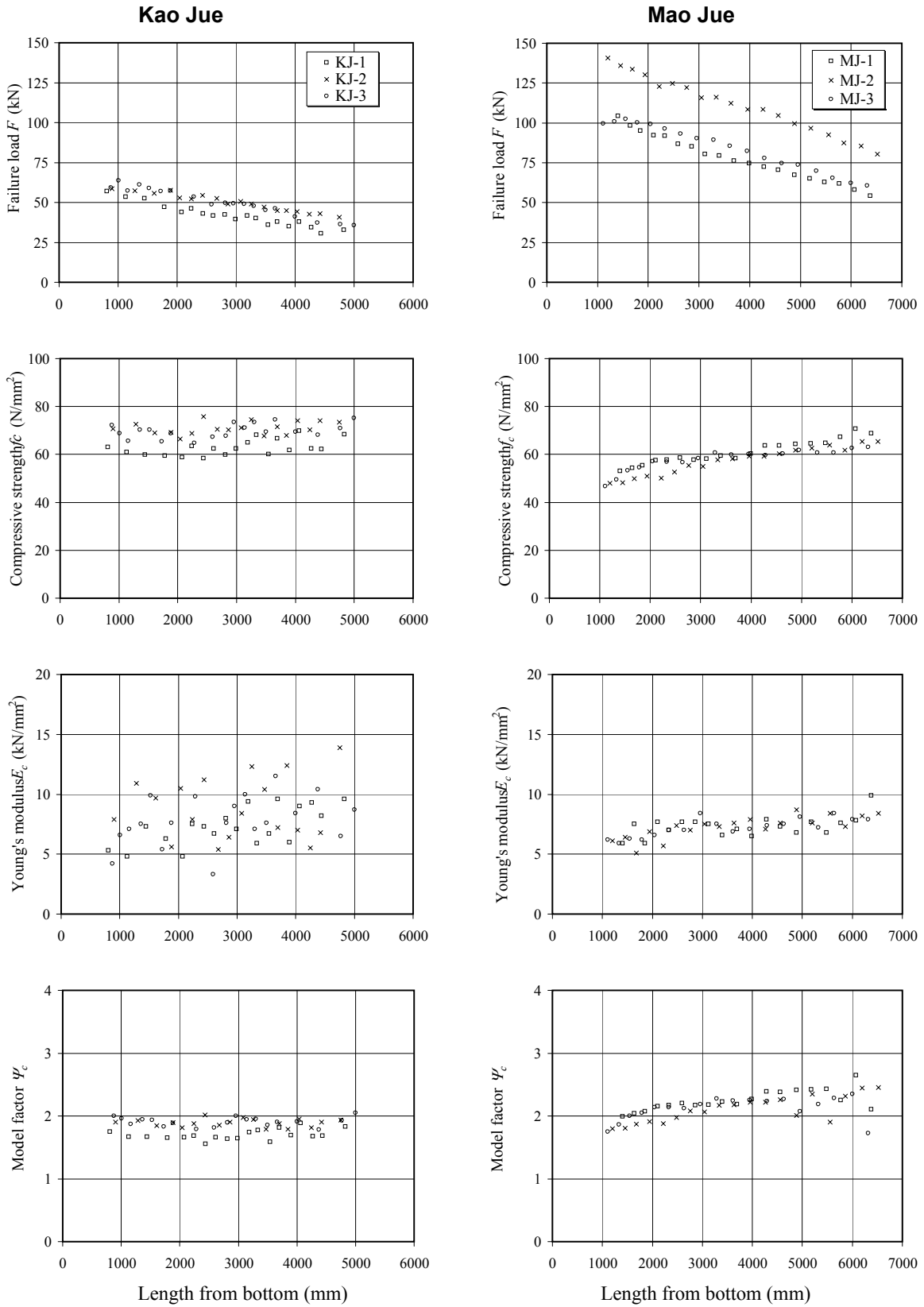
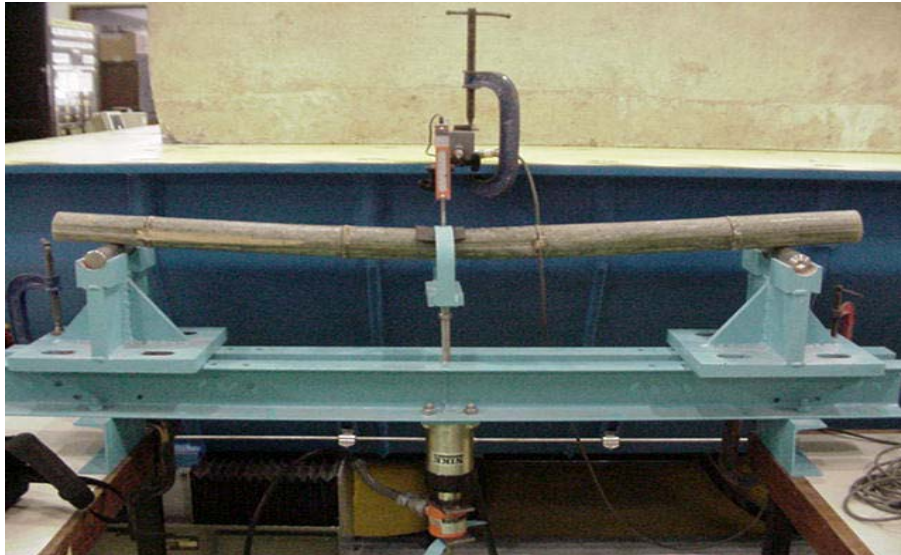
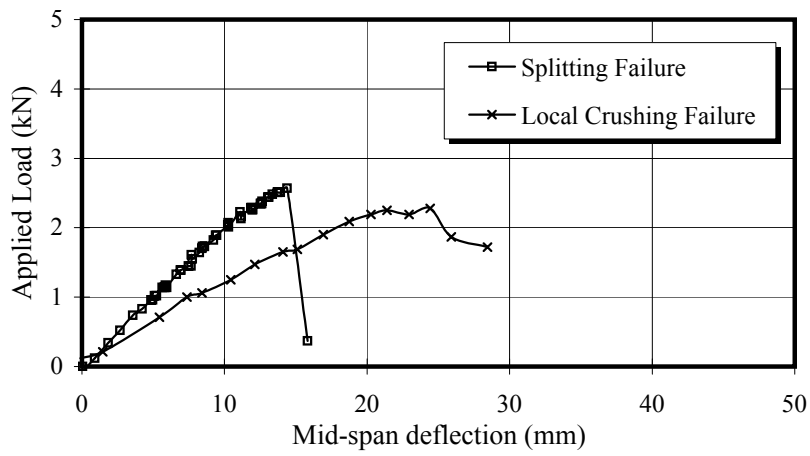

Figure 2.3 Variation of mechanical properties along length of bamboo culms



a) General test set-up



b) Load deflection curves

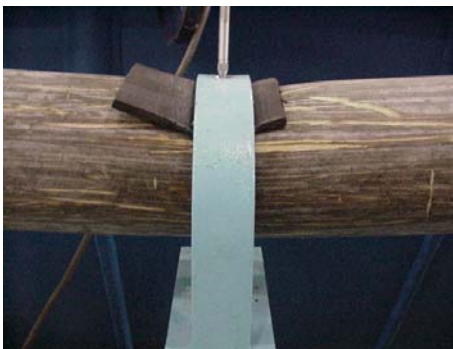

c) Typical failure mode - Local crushing

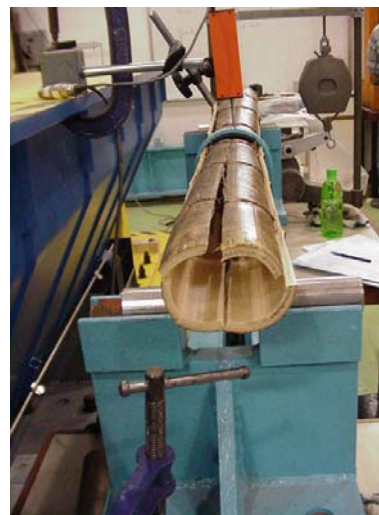

d) Typical failure mode - Splitting

Figure 2.4 Bending test

Figure 2.5 Variation of mechanical properties of Kao Jue against moisture content

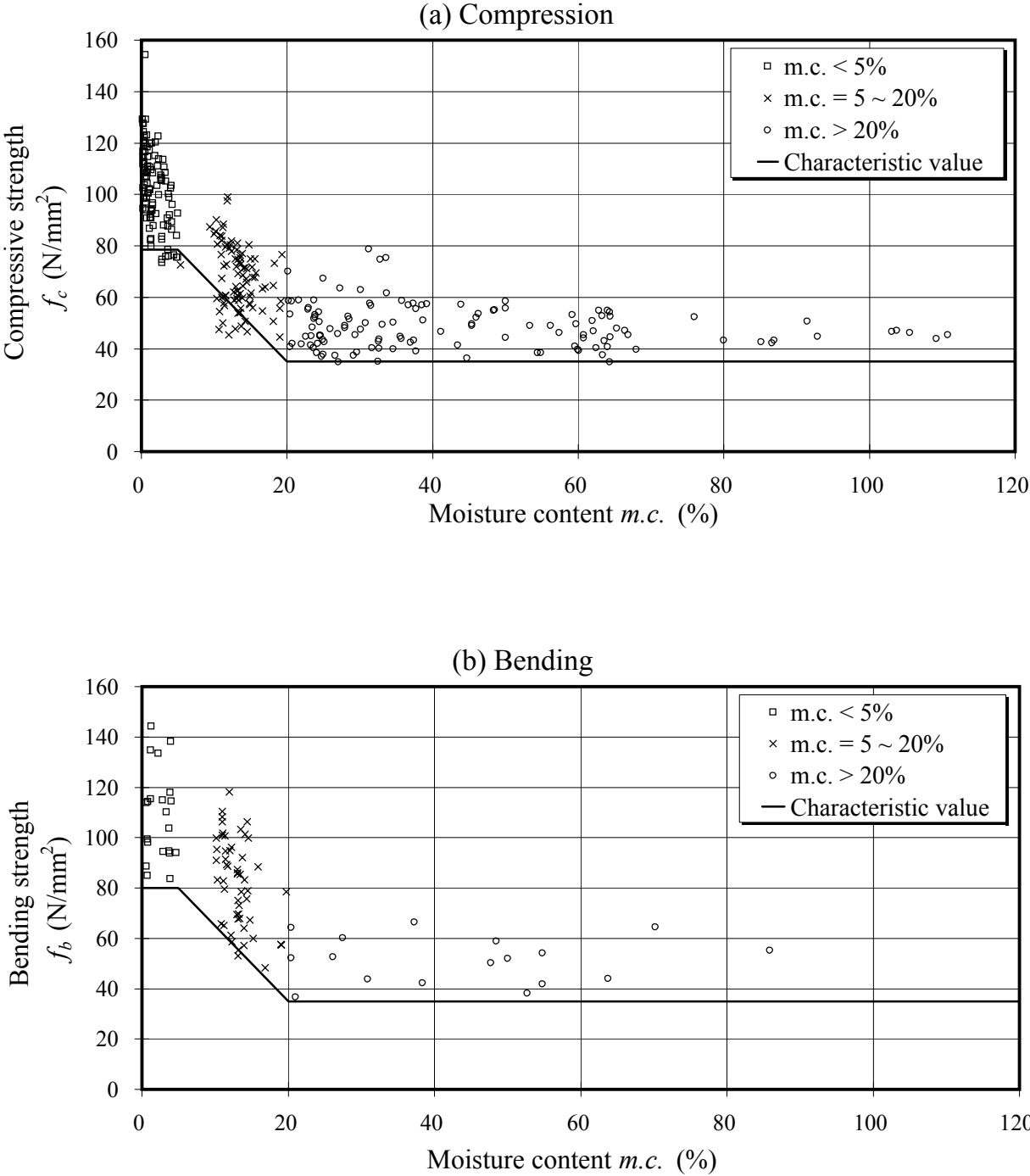

Figure 2.6 Variation of mechanical properties of Mao Jue against moisture content

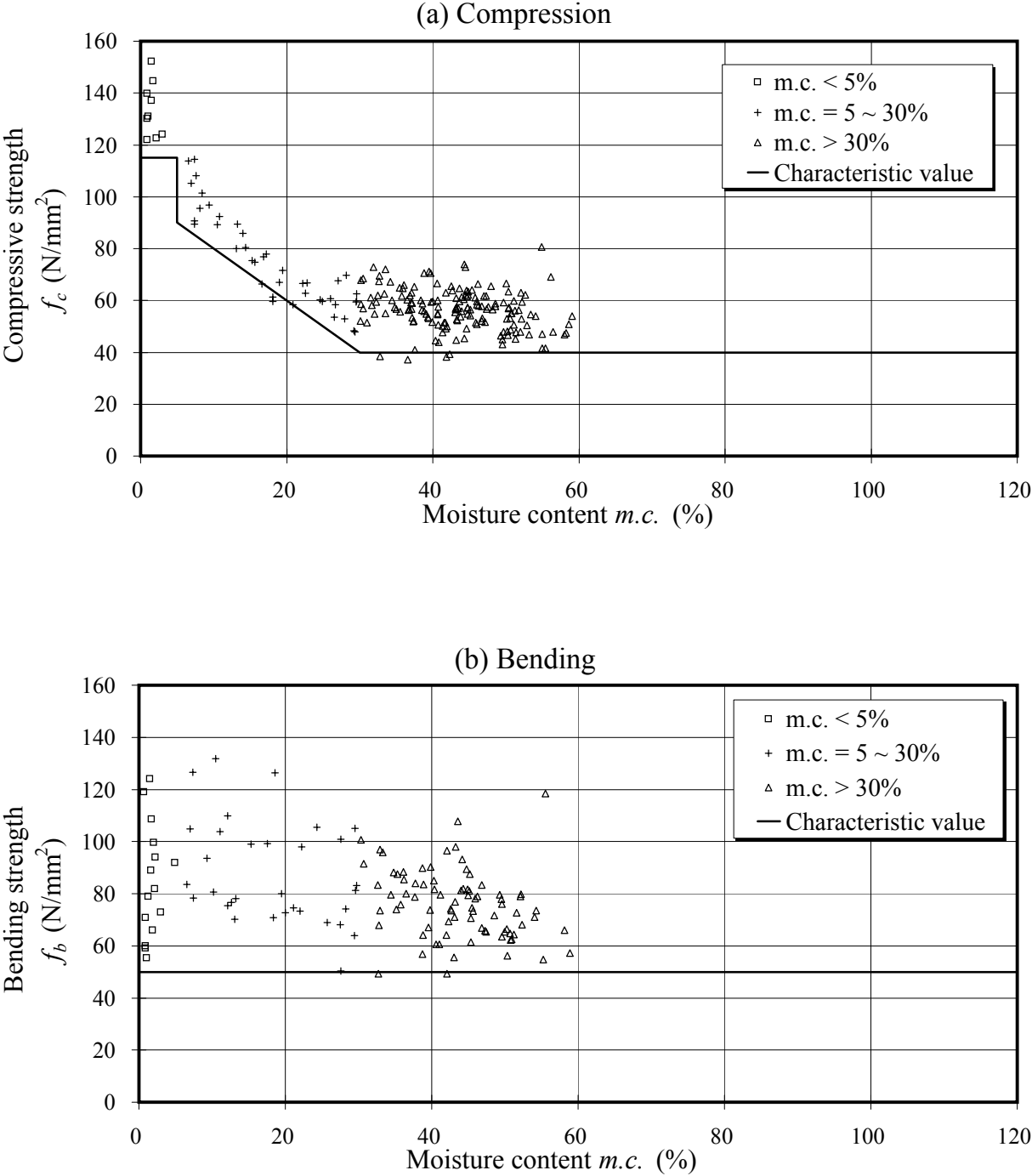

Figure 2.7 Variation of mechanical properties of Kao Jue against moisture content

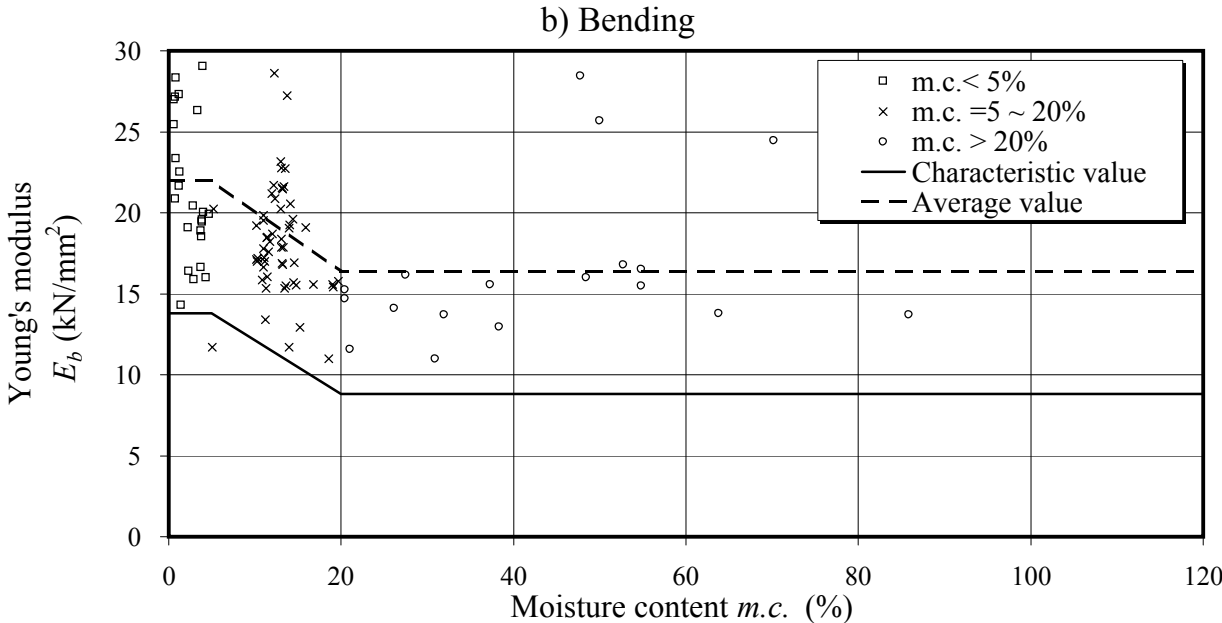
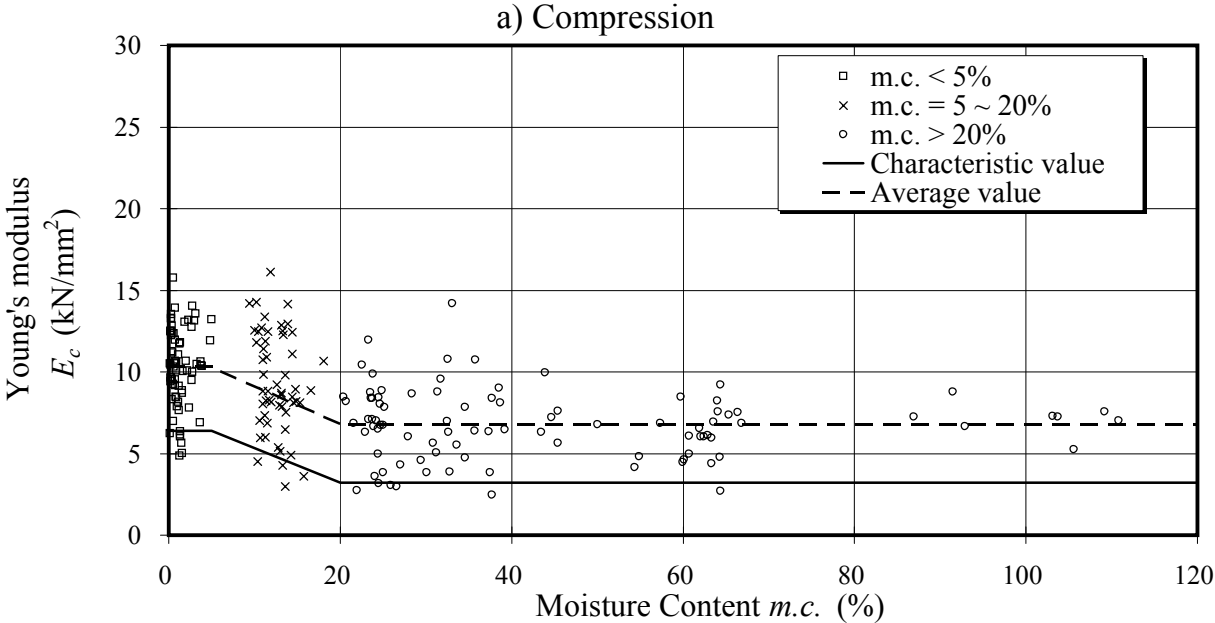

Figure 2.8 Variation of mechanical properties of Mao Jue against moisture content

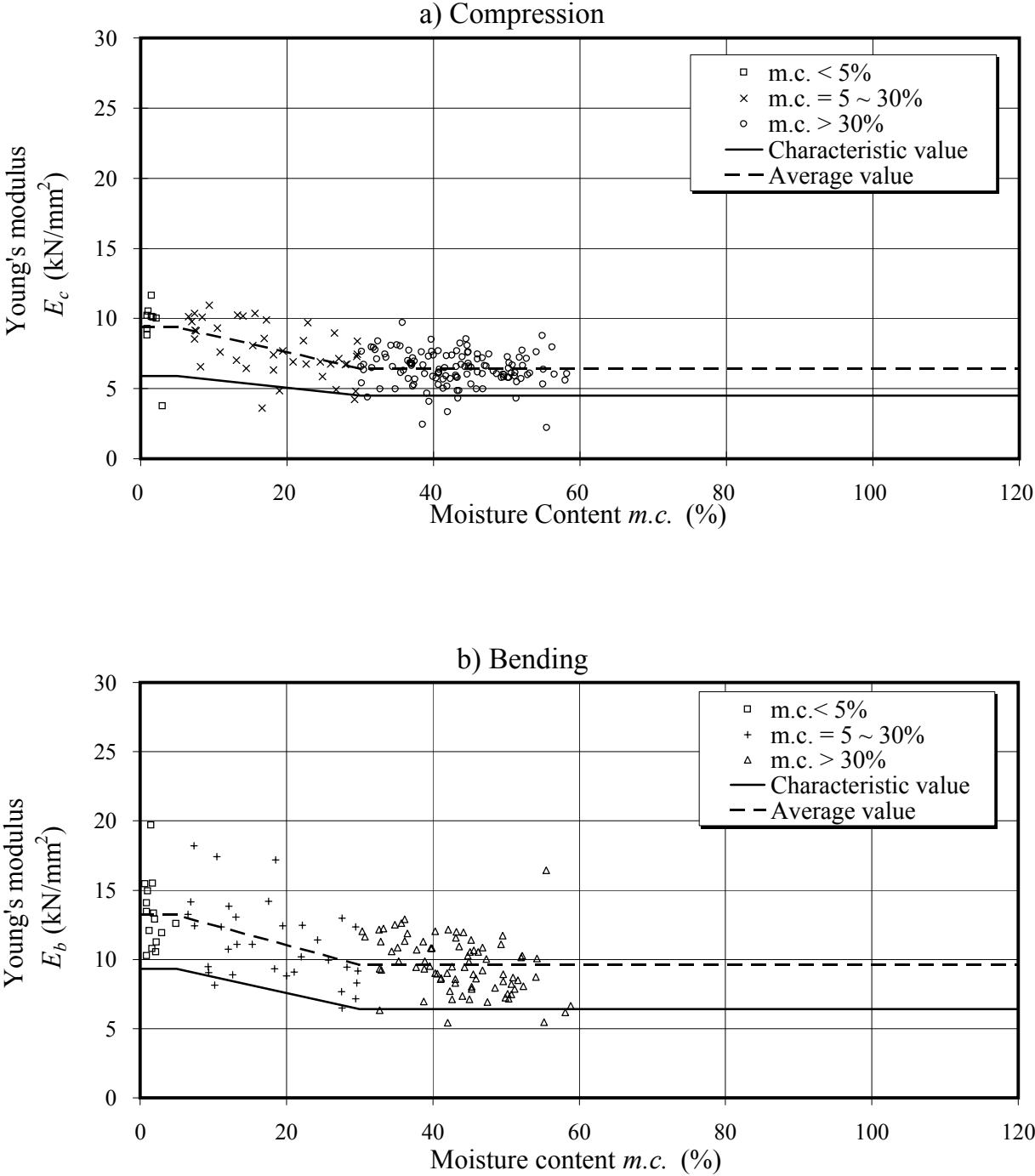

Figure 2.9 Variation of model factors of Kao Jue against moisture content

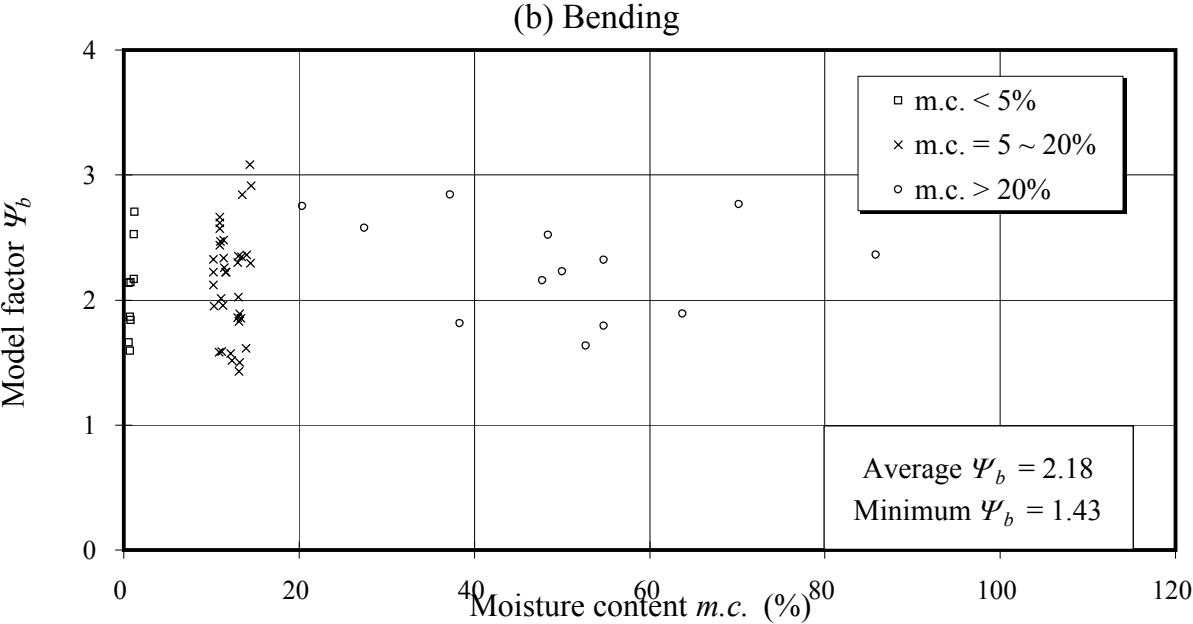
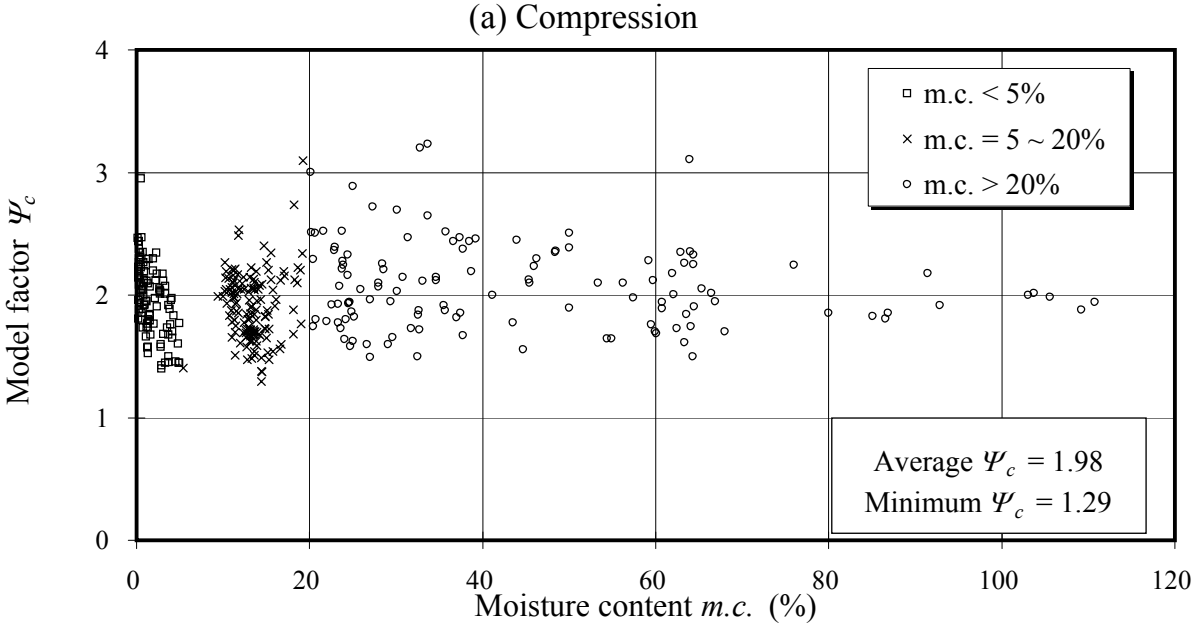

Figure 2.10 Variation of model factors of Mao Jue against moisture content

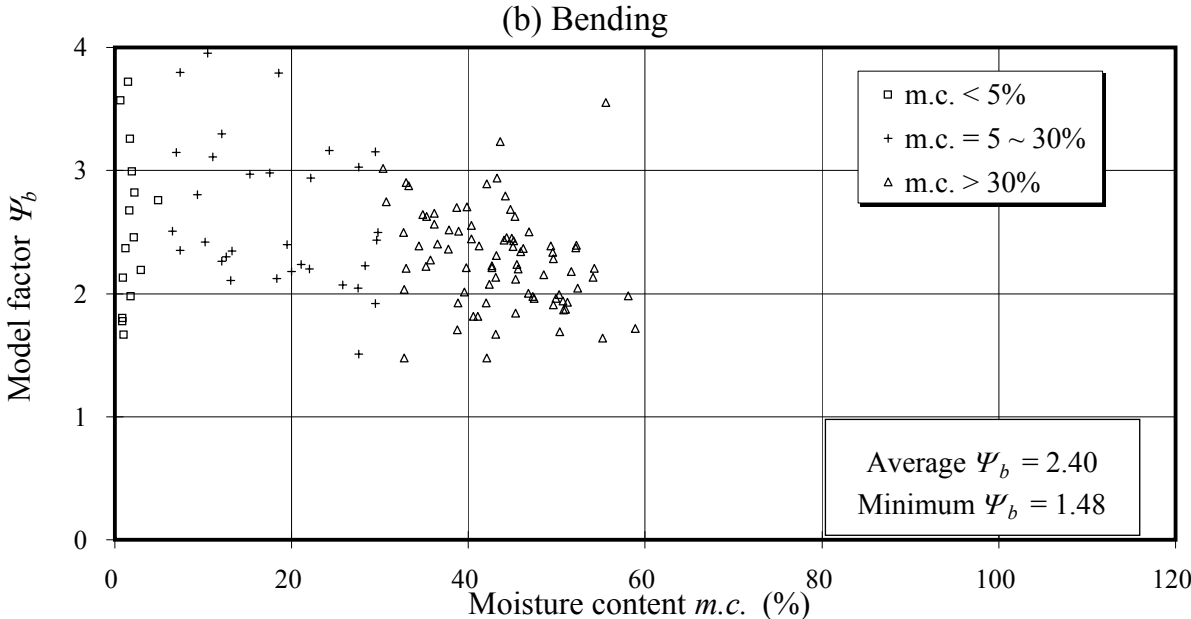
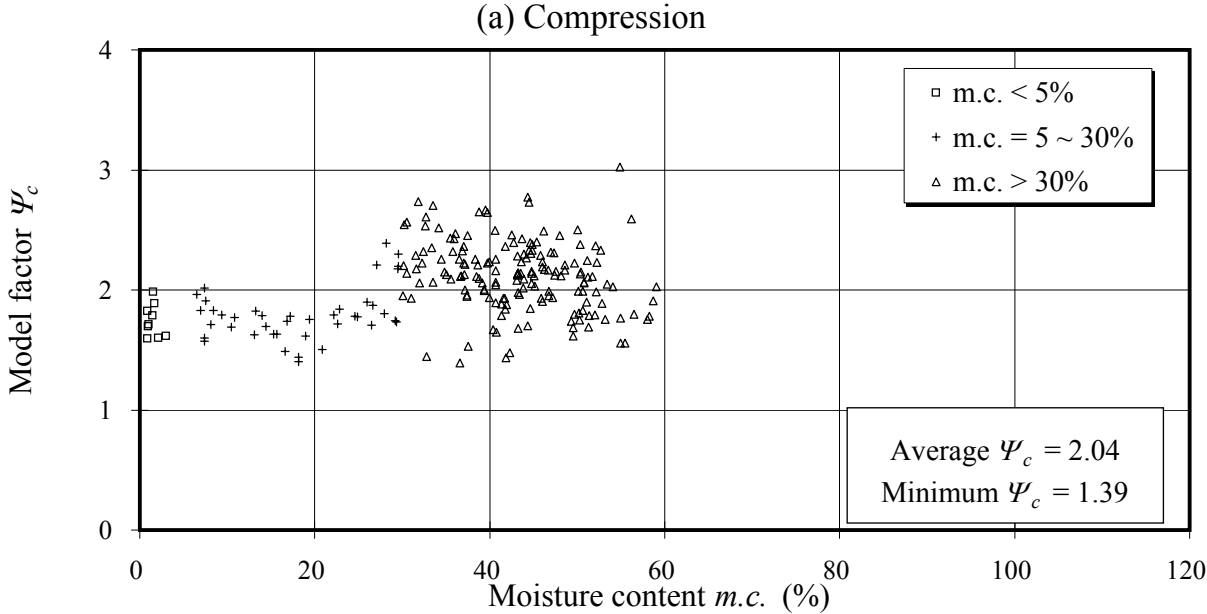

Figure 2.11 Design data of the dimensions of Kao Jue and Mao Jue

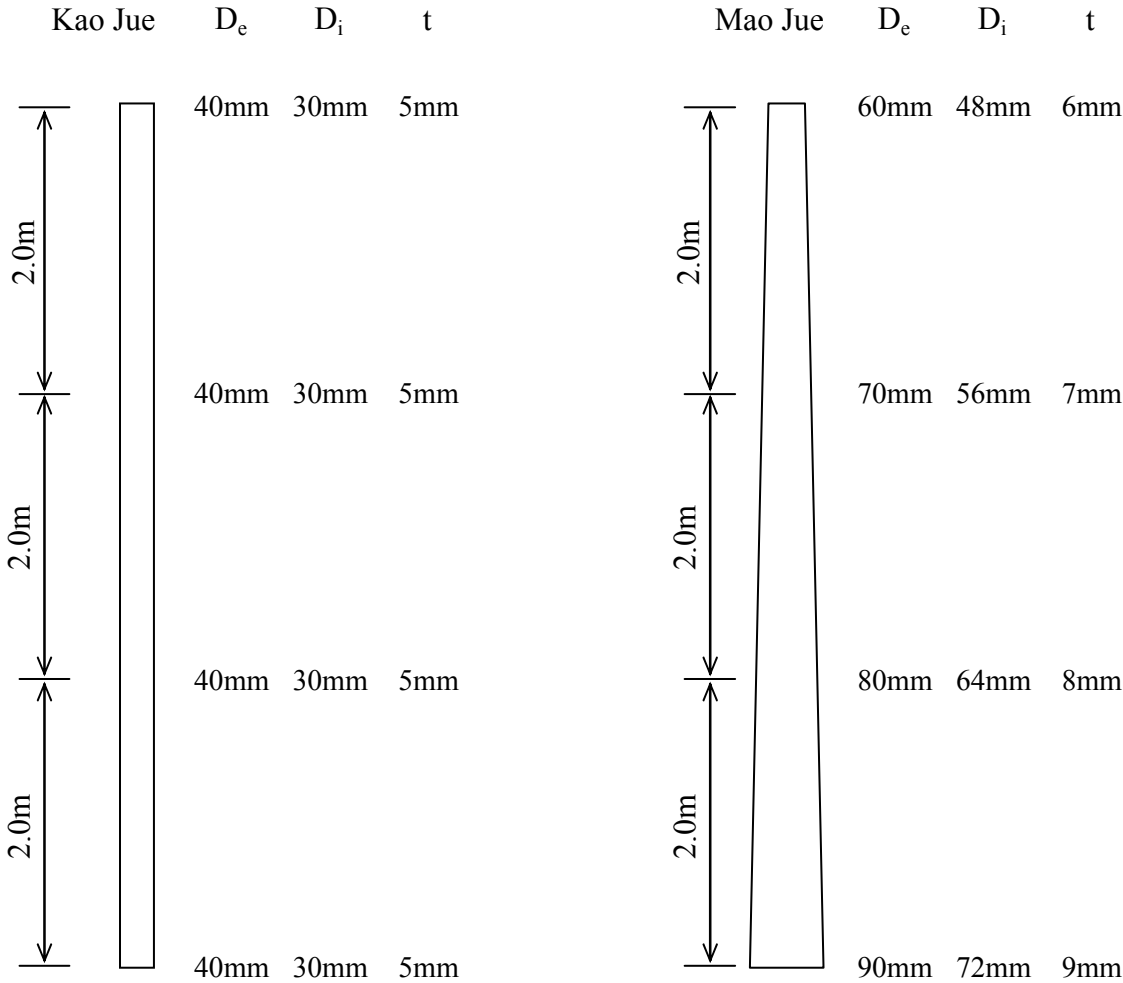

Table 2.1a Summary of physical and mechanical properties of *Bambusa Pervariabilis* (Kao Jue)

| | Nos. | Range | Maximum | Minimum | Average | Standard deviation |
|---|------|----------------------|--------------------|--------------------|--------------------|--------------------|
| External diameter D (mm) | 364 | All specimens | 57.6 | 23.9 | 40.7 | 5.9 |
| Internal diameter d (mm) | 364 | All specimens | 45.2 | 17.3 | 30.4 | 4.5 |
| Wall thickness t (mm) | 364 | All specimens | 10.7 | 2.9 | 5.2 | 1.4 |
| Cross-sectional area A (mm ²) | 364 | All specimens | 1375 | 213 | 589 | 207 |
| Second moment area I (mm ⁴) | 364 | All specimens | 37.3×10^4 | 1.16×10^4 | 10.4×10^4 | 6.01×10^4 |
| Dry density ρ (kg/m ³) | 364 | All specimens | 1731.6 | 522.0 | 708.8 | 87.02 |
| Moisture content $m.c.$ (%) | 103 | $m.c. < 5\%$ | 5.0 | 0.2 | 1.8 | 1.4 |
| | 136 | $m.c. = 5 \sim 20\%$ | 19.3 | 5.4 | 13.4 | 2.3 |
| | 125 | $m.c. > 20\%$ | 110.8 | 20.2 | 44.3 | 22.1 |
| Compressive strength f_c (N/mm ²) | 103 | $m.c. < 5\%$ | 154 | 73 | 103 | 15 |
| | 136 | $m.c. = 5 \sim 20\%$ | 99 | 44 | 69 | 12 |
| | 125 | $m.c. > 20\%$ | 75 | 35 | 48 | 8 |
| Young's modulus E_c (kN/mm ²) | 70 | $m.c. < 5\%$ | 15.8 | 4.9 | 10.3 | 2.4 |
| | 100 | $m.c. = 5 \sim 20\%$ | 16.1 | 2.5 | 9.3 | 2.9 |
| | 90 | $m.c. > 20\%$ | 14.2 | 2.2 | 6.8 | 2.2 |
| Bending strength f_b (N/mm ²) | 21 | $m.c. < 5\%$ | 144 | 84 | 109 | 17 |
| | 53 | $m.c. = 5 \sim 20\%$ | 118 | 48 | 82 | 17 |
| | 17 | $m.c. > 20\%$ | 66 | 37 | 52 | 9 |
| Young's modulus E_b (kN/mm ²) | 21 | $m.c. < 5\%$ | 35.3 | 14.3 | 22.0 | 5.0 |
| | 53 | $m.c. = 5 \sim 20\%$ | 39.3 | 11.0 | 18.5 | 4.3 |
| | 17 | $m.c. > 20\%$ | 28.5 | 11.0 | 16.4 | 4.7 |

Table 2.1b Summary of physical and mechanical properties of *Phyllostachys Pubescens* (Mao Jue)

| | Nos. | Range | Maximum | Minimum | Average | Standard deviation |
|---|------|----------------------|-------------------|--------------------|--------------------|--------------------|
| External diameter D (mm) | 213 | All specimens | 95.4 | 39.4 | 68.6 | 11.6 |
| Internal diameter d (mm) | 213 | All specimens | 74.2 | 27.6 | 54.5 | 9.6 |
| Wall thickness t (mm) | 213 | All specimens | 11.0 | 4.7 | 7.1 | 1.3 |
| Cross-sectional area A (mm ²) | 213 | All specimens | 2831 | 578 | 1397 | 468 |
| Second moment area I (mm ⁴) | 213 | All specimens | 258×10^4 | 9.00×10^4 | 76.1×10^4 | 9.32×10^4 |
| Dry density ρ (kg/m ³) | 213 | All specimens | 1286.5 | 463.5 | 793.9 | 108.3 |
| Moisture content $m.c.$ (%) | 9 | $m.c. < 5\%$ | 3.0 | 0.9 | 1.5 | 0.7 |
| | 41 | $m.c. = 5 \sim 30\%$ | 29.6 | 6.5 | 18.3 | 7.8 |
| | 163 | $m.c. > 30\%$ | 59.1 | 30.1 | 43.4 | 7.0 |
| Compressive strength f_c (N/mm ²) | 9 | $m.c. < 5\%$ | 152 | 122 | 134 | 10 |
| | 41 | $m.c. = 5 \sim 30\%$ | 114 | 48 | 75 | 18 |
| | 163 | $m.c. > 30\%$ | 81 | 37 | 57 | 8 |
| Young's modulus E_c (kN/mm ²) | 9 | $m.c. < 5\%$ | 11.7 | 3.8 | 9.4 | 2.1 |
| | 41 | $m.c. = 5 \sim 30\%$ | 11.0 | 3.6 | 7.8 | 1.9 |
| | 163 | $m.c. > 30\%$ | 9.7 | 2.2 | 6.4 | 1.2 |
| Bending strength f_b (N/mm ²) | 15 | $m.c. < 5\%$ | 124 | 56 | 85 | 21 |
| | 32 | $m.c. = 5 \sim 30\%$ | 50 | 132 | 88 | 19 |
| | 81 | $m.c. > 30\%$ | 118 | 49 | 76 | 13 |
| Young's modulus E_b (kN/mm ²) | 15 | $m.c. < 5\%$ | 19.7 | 10.3 | 13.2 | 2.4 |
| | 32 | $m.c. = 5 \sim 30\%$ | 18.2 | 7.1 | 11.4 | 2.8 |
| | 81 | $m.c. > 30\%$ | 16.4 | 5.4 | 9.6 | 2.0 |

Table 2.2 Proposed mechanical properties for *Bambusa Pervariabilis* (Kao Jue) and *Phyllostachys Pubescens* (Mao Jue)

| Bamboo species | | Compression | | | Bending | | |
|---|--|---------------------------------|------|-----|---------------------------------|------|------|
| | | | Dry | Wet | | Dry | Wet |
| <i>Bambusa Pervariabilis</i> (Kao Jue) | Characteristic strength (at fifth percentile) | $f_{c,k}$ (N/mm ²) | 79 | 35 | $f_{b,k}$ (N/mm ²) | 80 | 37 |
| | Design strength ($\gamma_m = 1.5$) | $f_{c,d}$ (N/mm ²) | 53 | 23 | $f_{b,d}$ (N/mm ²) | 53 | 25 |
| | Design Young's modulus (Average value) | $E_{c,d}$ (kN/mm ²) | 10.3 | 6.8 | $E_{b,d}$ (kN/mm ²) | 22.0 | 16.4 |
| <i>Phyllostachys Pubescens</i> (Mao Jue) | Characteristic strength (at fifth percentile) | $f_{c,k}$ (N/mm ²) | 117 | 44 | $f_{b,k}$ (N/mm ²) | 51 | 55 |
| | Design strength ($\gamma_m = 1.5$) | $f_{c,d}$ (N/mm ²) | 78 | 29 | $f_{b,d}$ (N/mm ²) | 34 | 37 |
| | Design Young's modulus (Average value) | $E_{c,d}$ (kN/mm ²) | 9.4 | 6.4 | $E_{b,d}$ (kN/mm ²) | 13.2 | 9.6 |

Notes: Dry condition *m.c.* < 5 % for both Kao Jue and Mao Jue.

Wet condition *m.c.* > 20 % for Kao Jue, and

m.c. > 30 % for Mao Jue.

Linear interpolation is permitted for mechanical properties with moisture contents between dry and wet conditions.

The shear strengths of both Kao Jue and Mao Jue are conservatively estimated as $0.25f_{c,d}$ but not less than 6 N/mm² nor greater than 15 N/mm².

3. Column buckling of structural bamboo

3.1 Introduction

Traditionally, bamboo scaffolds are erected by scaffolding practitioners through their practical experiences without any scientifically based design. In general, column buckling is considered to be one of the critical modes of failure in bamboo scaffolds, leading to overall structural collapse. After the determination of the compression and the bending capacities of structural bamboo, this Chapter presents the design development of a limit state design method against column buckling of structural bamboo. The main objectives of the design development are:

- To provide test data for the column buckling behaviour of both Kao Jue and Mao Jue over practical ranges of physical and mechanical properties.
- To develop a rational design method against column buckling of bamboo members.
- To assess the structural accuracy of the design method through calibration of test data.

A total of 72 column buckling tests for both Kao Jue and Mao Jue over a practical range of height-to-diameter ratios, diameter variations over member length, and also moisture content are executed to provide test data. A column buckling design method for both Kao Jue and Mao Jue is proposed for general design after calibration against test data. Due to large variations of the physical properties along the length of bamboo members, it is important to incorporate the non-prismatic effect in assessing their axial buckling resistances.

3.2 Experimental investigations

In order to provide test data for the column buckling behaviour of both Kao Jue and Mao Jue over practical ranges of physical and mechanical properties, two test series were performed. In each test series, 36 column buckling tests of bamboo members with three different member lengths and a number of compression tests on short bamboo culms were carried out under both natural and wet conditions. The test specimens for the column buckling tests are selected and prepared as follows:

- A bamboo culm is around 6 metres in length and of 3 to 6 years of age.
- A length of 750 mm from both the top and the bottom ends are discarded.
- Three specimens are cut from the top, the middle and the bottom positions of the culm and marked with the letters *A*, *B* and *C* respectively.

The bamboo members are tested under two different conditions of moisture content, namely, natural and wet conditions. The natural condition is denoted as *N* and it represents the typical range of moisture contents to be found in practice. The wet condition is denoted as *W* and it represents the extreme range of moisture content approaching water saturation in the bamboo fibers; the test specimens are immersed under water for one week before testing. Three member lengths are selected, and they are 400, 600 and 800mm for Kao Jue and 1000, 1500

and 2000 mm for Mao Jue; the member lengths are denoted as a , b and c respectively. Kao Jue and Mao Jue are denoted as K and M respectively. The designation system for the test specimens are defined as follows:

$$\left\{ \begin{matrix} K \\ M \end{matrix} \right\} \left\{ \begin{matrix} A \\ B \\ C \end{matrix} \right\} \left\{ \begin{matrix} N \\ W \end{matrix} \right\} \left\{ \begin{matrix} a \\ b \\ c \end{matrix} \right\} \left\{ \begin{matrix} 1 \\ 2 \end{matrix} \right\}$$

The total number of tests is equal to $2 \times 3 \times 2 \times 3 \times 2$ or 72. Tables 3.1 and 3.2 present the details of the test series for both Kao Jue and Mao Jue respectively. The general set-up of the column buckling tests is illustrated in Figure 3.1.

In order to simplify data analysis, smooth ball joints were used to provide pinned end conditions at both supports, thus the effective length coefficient of all the test specimens was taken as 1.0. The applied load P , the axial shortening, w , and the horizontal displacements, u and v were measured continuously during the test to provide load-deflection curves for data analysis, and the maximum applied load and the corresponding displacements at failure were obtained for each test.

3.3 Typical failure modes

Two failure modes, namely *overall buckling* and *local buckling*, are identified among the tests, and they are shown in Figure 3.2. It is found that most Mao Jue members fail in overall buckling, especially for those long columns with high moisture contents. For wet and short columns of Kao Jue, local buckling is critical.

After each buckling test, at least two short culms were cut out from the member and compression tests on the short culms were carried out to evaluate the compressive strengths of the bamboo members. The length of each compression test specimen was about twice the external diameter of the bamboo culm, but not larger than 75 and 150 mm for Kao Jue and Mao Jue respectively.

3.4 Test results

The measured failure loads of all the specimens are presented in Tables 3.1 and 3.2 while typical load-deflection curves of the test specimens are plotted in Figure 3.3. It is shown that load reduction due to lateral buckling of the test specimens are severe, and thus it is necessary to derive a suitable design method in order to assess the axial buckling resistances of long columns in typical applications.

3.5 Column buckling design

Based on modern structural design philosophy, a design method is proposed for column buckling of both Kao Jue and Mao Jue in a limit state design format. The compressive buckling strength of structural bamboo is expressed as a factor of the compressive strength,

and the reduction due to column buckling is a function of the modified slenderness ratio of the column member. It should be noted that the formulation of the proposed design method follows the steel column buckling method given in BS5950: Part 1: 2000 where a Perry-Robertson interaction formula is used to evaluate the compressive buckling strength of steel columns. Moreover, a number of buckling curves is available with different values of Robertson constant for selection in designing steel columns of different cross-sections under different axes of buckling.

As natural non-homogenous organic materials, large variations of physical properties along the length of bamboo members such as external and internal diameters are apparent. Thus, the non-prismatic effect is significant in the column buckling analysis, and this may be readily achieved by incorporating a non-prismatic parameter, α , to the elastic Euler buckling load of the bamboo member. The non-prismatic parameter α is a function of the change of the second moment of area along member length, and it may be evaluated through the minimum energy method.

The proposed design method is presented as follows:

i) Basic section properties of a bamboo column are evaluated first:

$$A_1 = \frac{\pi}{4}(D_e^2 - D_i^2)$$

$$I_1 = \frac{\pi}{64}(D_e^4 - D_i^4)$$

$$\text{Slenderness ratio, } \lambda_1 = \frac{L_E}{r_1} \text{ where } r_1 = \sqrt{\frac{I_1}{A_1}}$$

where subscripts 1 and 2 denote the upper (smaller) cross-section and the lower (larger) cross-section respectively.

ii) The elastic critical buckling strength of the bamboo column, p_{cr} , is given by:

$$p_{cr} = \alpha \cdot \frac{\pi^2 E_b}{\lambda_1^2}$$

where the non-prismatic parameter, α , is the minimum root of the following cubic function,

$$f(\alpha) = c_3\alpha^3 + c_2\alpha^2 + c_1\alpha + c_0 = 0$$

where

$$c_3 = -0.2880$$

$$c_2 = 2.016(2 + \rho)$$

$$c_1 = -(14.11 + 14.11\rho + 3.098\rho^2)$$

$$c_0 = 10.37 + 15.55\rho + 7.047\rho^2 + 0.932\rho^3$$

$$\rho = \frac{I_2}{I_1} - 1$$

The solution of $f(\alpha)$ is tabulated in Table 3.3 for practical design. If the value of ρ lies between 0 and 3, the value of α may be evaluated approximately as follows:

$$\alpha = 1.005 + 0.4751\rho - 0.011\rho^2 \text{ where } \alpha \text{ lies between 1.00 and 2.35.}$$

iii) The compressive strength of the bamboo column, p_c , is given by:

$$p_c = \frac{P_{c,k}}{\gamma_M}$$

iv) The compressive buckling strength of the bamboo column is thus given by:

$$p_{c,e} = \frac{P_{cr} P_c}{\phi + (\phi^2 - P_{cr} P_c)^{1/2}}$$

where

$$\phi = \frac{p_c + (1 + \eta)p_{cr}}{2}$$

Perry factor, $\eta = 0.001 a (\lambda_1 - \lambda_0)$

Robertson constant, $a = 15$ for Mao Jue, or 28 for Kao Jue, depending on magnitudes of initial imperfection

$$\text{Limiting slenderness ratio, } \lambda_0 = 0.2\pi \sqrt{\frac{E_b}{p_c}}$$

A column buckling curve may be plotted for the following two non-dimensionalized quantities:

- Modified slenderness ratio, $\bar{\lambda} = \sqrt{\frac{p_c}{P_{cr}}}$
- Strength reduction factor, $\bar{\psi}_c = \frac{p_{c,e}}{p_c}$

For practical design, the strength reduction factor may be obtained directly from Table 3.4 once the modified slenderness ratio is known.

3.6 Calibration of design method

In order to calibrate the proposed design method, a back analysis against the test data was carried out with all partial safety factors equal to unity. Furthermore, the measured compressive strengths of test specimens under natural and wet conditions were adopted, and the measured dimensions of the test specimens were used. Meanwhile, the design values of Young's moduli against bending of both Kao Jue and Mao Jue as given in Table 2.2 were used in the back analysis. Figure 3.4 presents the proposed column buckling curves for both Kao Jue and Mao Jue, and the test data is also plotted on the same graph for direct comparison. Tables 3.1 and 3.2 also summarize the test results for both Kao Jue and Mao Jue.

For Kao Jue, it is found that due to the presence of large initial imperfection when compared with its diameter, the Robertson constant is selected to be 28 in order to yield safe design for all test results. The measured modified slenderness ratios are found to range from 0.44 to 1.11 while the measured strength reduction ratios are found to range from 0.31 to 1.31 .

For Mao Jue, the Robertson constant is selected to be 15 due to small initial imperfection. The measured modified slenderness ratios are found to range from 0.66 to 2.22 and the measured strength reduction ratios are found to range from 0.23 to 0.93. In the present study, the value of non-prismatic parameter, α , is found to range from 1.04 to 2.11 for Mao Jue and from 1.00 to 1.28 for Kao Jue.

The model factors for the proposed design method of column buckling against the test data of both Kao Jue and Mao Jue are also presented in Tables 3.1 and 3.2 respectively. The distribution of the model factors for both Kao Jue and Mao Jue under different moisture conditions is plotted in Figure 3.5. For Kao Jue, the average model factor is equal to 1.63 and 1.86 for natural and wet conditions respectively. Similarly, the average model factor for Mao Jue is equal to 1.48 and 1.67 for natural and wet conditions respectively. Consequently, the proposed design method is shown to be adequate.

3.7 Conclusions

Based on a systematic experimental investigation on the column buckling behaviour of bamboo members, a limit state design method for Kao Jue and Mao Jue is developed and calibrated against test data. It is shown that the proposed design method against column buckling of structural bamboo is reliable and yet simple in assessing the axial buckling resistances of both Kao Jue and Mao Jue, and thus it is suitable to be used in bamboo scaffolds.

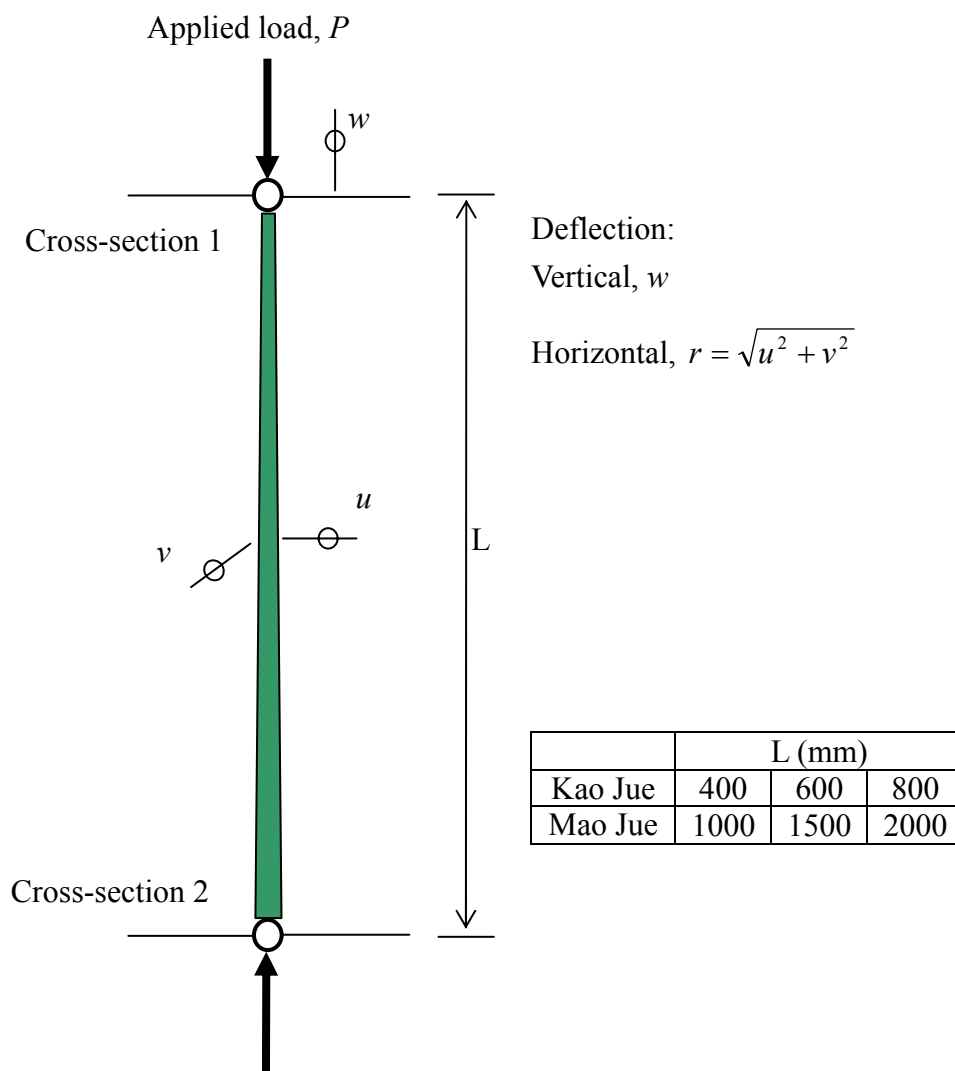

Figure 3.1 General setup of column buckling tests



a) Overall buckling



b) Local buckling

Figure 3.2 Failure modes of bamboo column

Figure 3.3a Typical load deflection curves of column buckling test (Kao Jue)

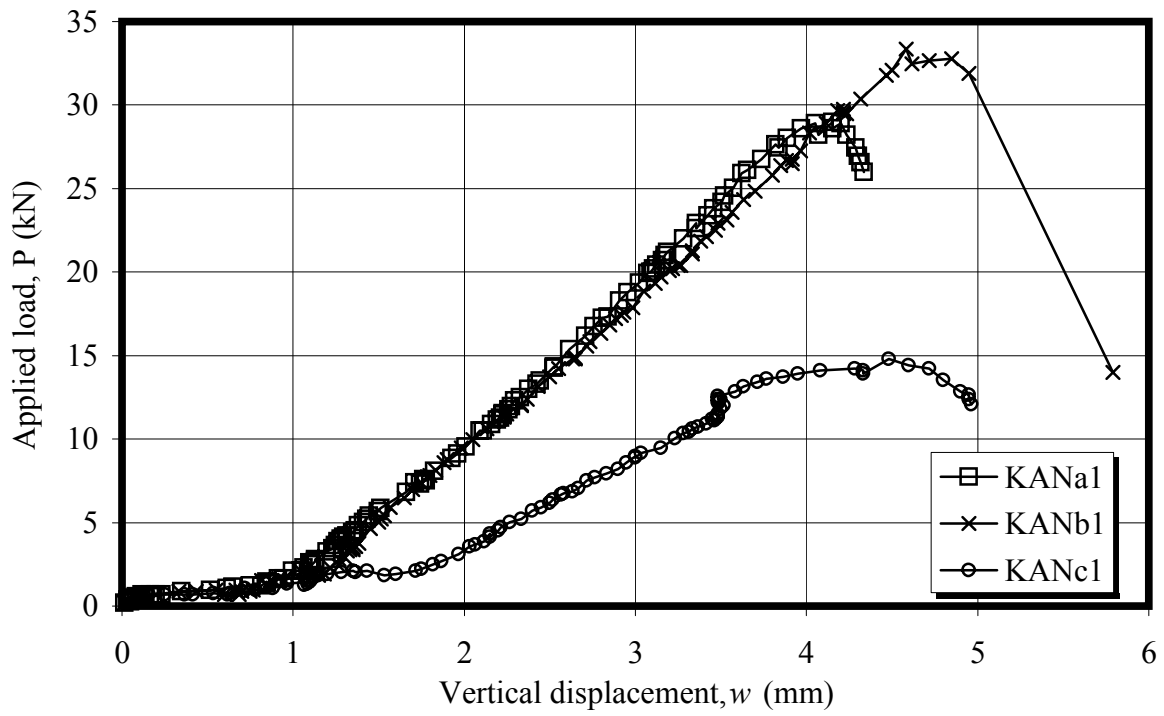

Figure 3.3b Typical load deflection curves of column buckling test (Mao Jue)

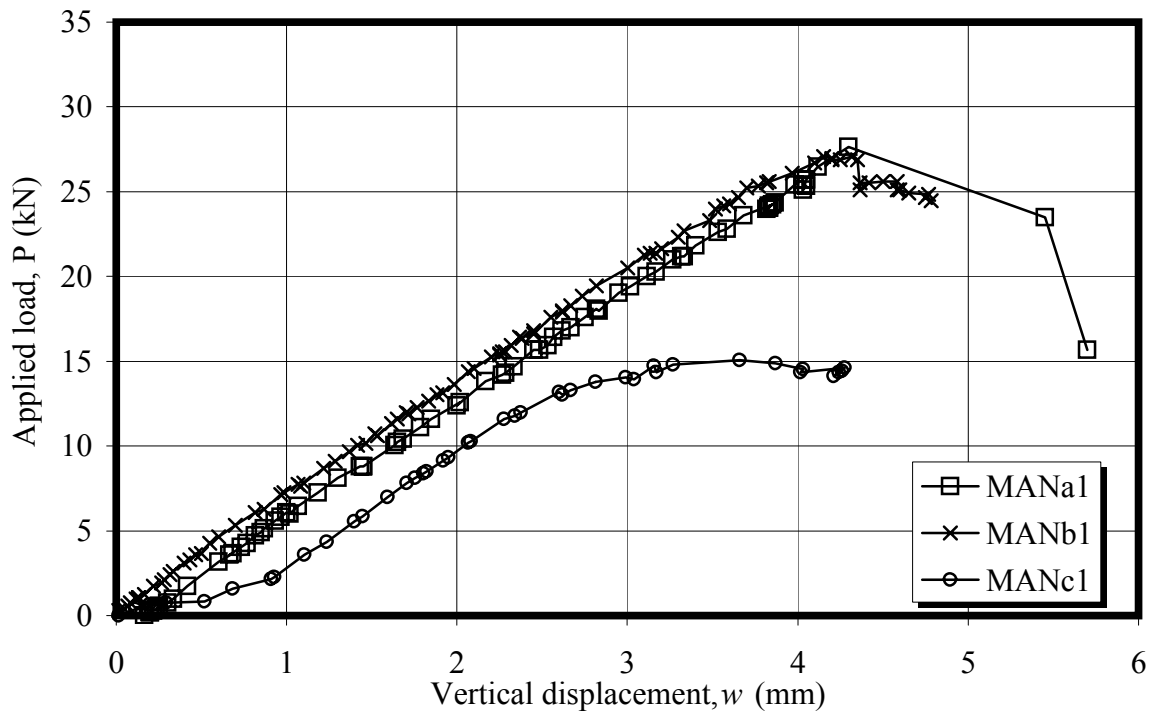
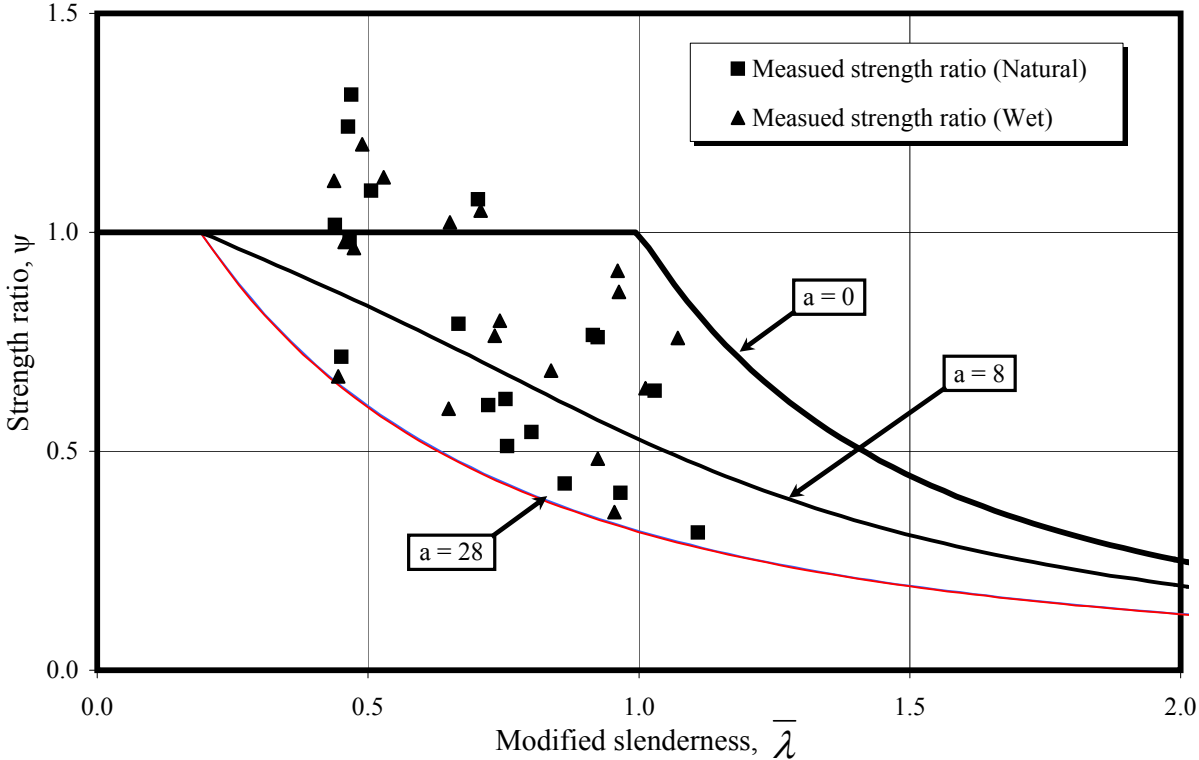

Figure 3.4 Column buckling analysis for Kao Jue and Mao Jue

a) Back analysis for Kao Jue



b) Back analysis for Mao Jue

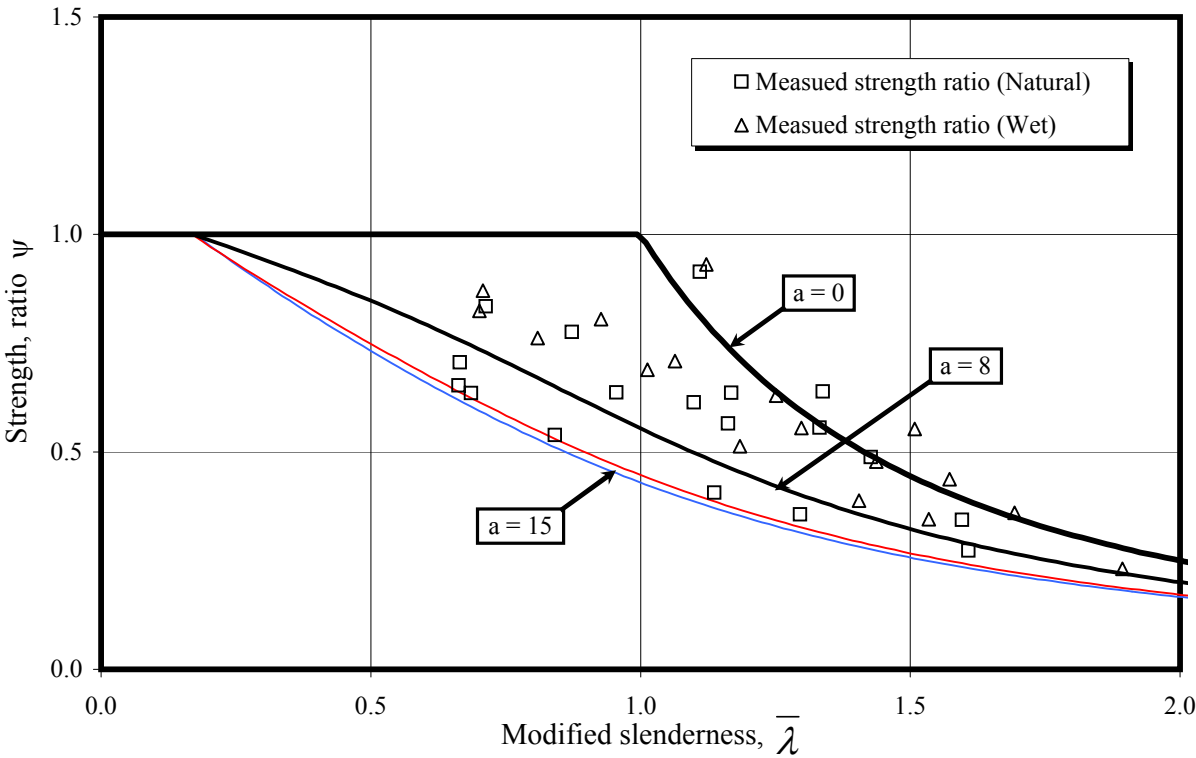

Figure 3.5 Model factors for column buckling design

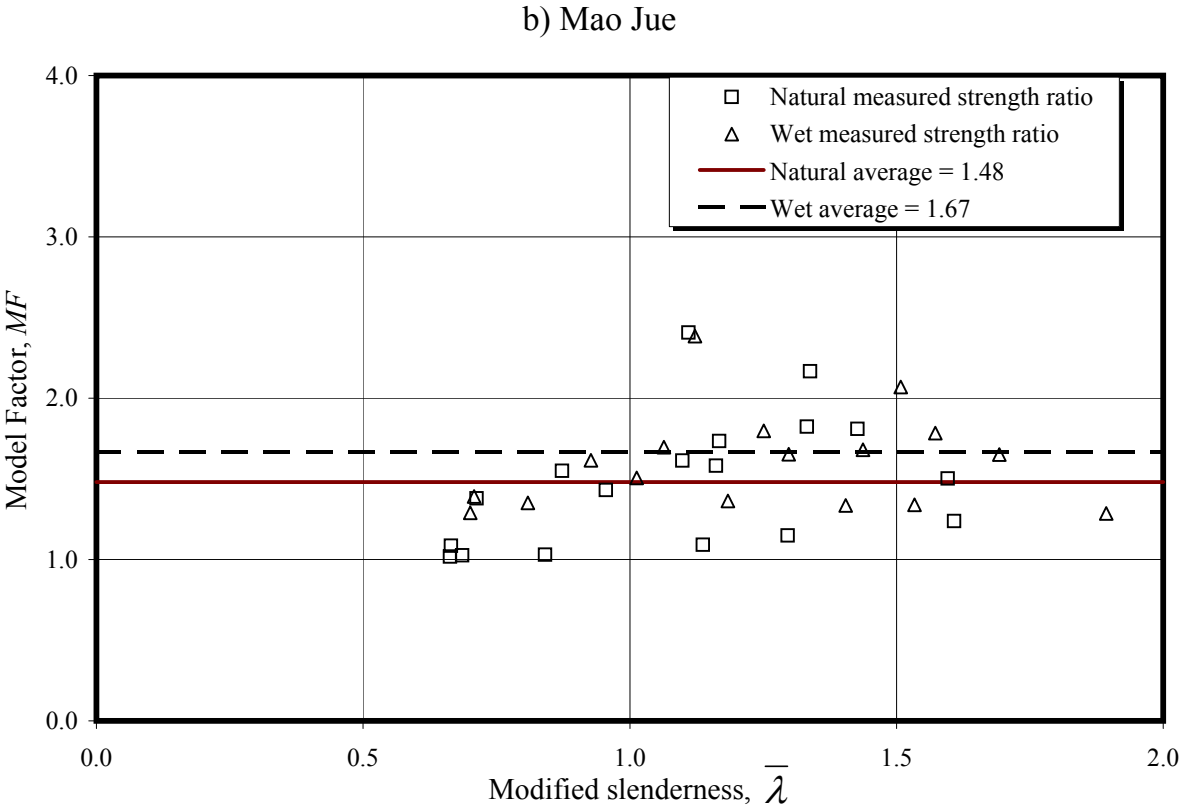
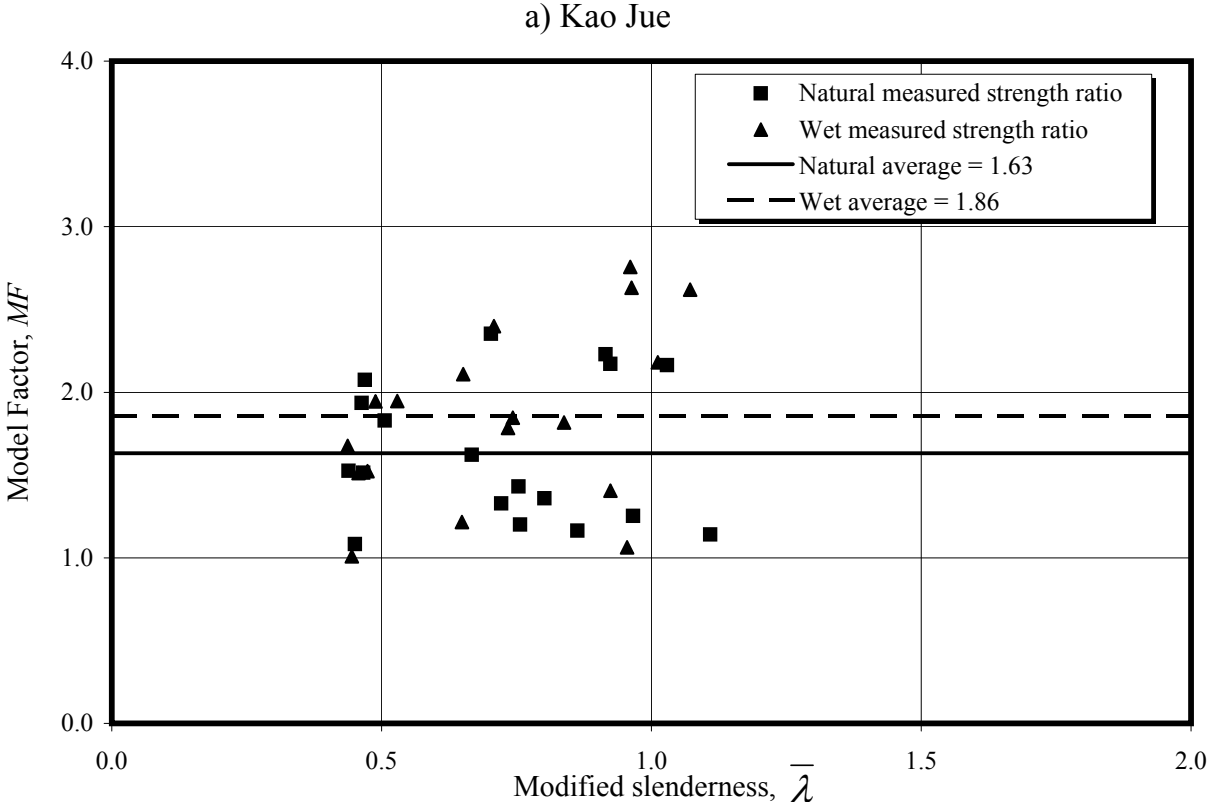

Table 3.1 Details of test series for Kao Jue

| Specimen | D ₁ (mm) | d ₁ (mm) | D ₂ (mm) | d ₂ (mm) | L (mm) | P _{test} (kN) | m.c. (%) | $p_{c,c}$ (N/mm ²) | $p_{c,t}$ (N/mm ²) | $\bar{\lambda}$ | $\bar{\psi}_C$ | $\bar{\psi}_T$ | MF |
|----------|------------------------|------------------------|------------------------|------------------------|-----------|---------------------------|-------------|-----------------------------------|-----------------------------------|-----------------|----------------|----------------|------|
| KANa1 | 38.77 | 30.02 | 39.82 | 30.23 | 401 | 28.99 | 12.0 | 33.5 | 61.3 | 0.51 | 0.60 | 1.10 | 1.83 |
| KBNa1 | 42.71 | 31.85 | 43.69 | 32.06 | 396 | 44.18 | 12.5 | 35.9 | 69.5 | 0.46 | 0.64 | 1.24 | 1.94 |
| KCNa1 | 45.14 | 30.52 | 44.86 | 28.72 | 398 | 47.65 | 12.5 | 36.2 | 54.8 | 0.47 | 0.65 | 0.98 | 1.51 |
| KANa2 | 41.02 | 33.23 | 42.48 | 34.42 | 399 | 33.44 | 11.6 | 35.5 | 73.6 | 0.47 | 0.63 | 1.31 | 2.08 |
| KBNa2 | 45.08 | 35.45 | 45.51 | 35.04 | 401 | 34.70 | 11.9 | 37.4 | 57.0 | 0.44 | 0.67 | 1.02 | 1.53 |
| KCNa2 | 45.14 | 33.69 | 44.08 | 31.44 | 398 | 28.42 | 12.5 | 37.0 | 40.1 | 0.45 | 0.66 | 0.72 | 1.08 |
| KANb1 | 41.82 | 32.31 | 43.68 | 34.39 | 598 | 33.34 | 11.9 | 25.6 | 60.2 | 0.70 | 0.46 | 1.08 | 2.35 |
| KBNb1 | 45.28 | 34.85 | 44.88 | 33.48 | 597 | 29.09 | 12.5 | 27.3 | 44.3 | 0.67 | 0.49 | 0.79 | 1.62 |
| KCNb1 | 43.69 | 30.16 | 43.18 | 28.71 | 598 | 26.58 | 12.5 | 25.5 | 33.9 | 0.72 | 0.46 | 0.61 | 1.33 |
| KANb2 | 36.38 | 27.91 | 37.33 | 27.68 | 598 | 13.04 | 11.5 | 22.4 | 30.5 | 0.80 | 0.40 | 0.54 | 1.36 |
| KBNb2 | 40.11 | 30.22 | 40.08 | 28.92 | 600 | 18.94 | 11.5 | 24.2 | 34.7 | 0.75 | 0.43 | 0.62 | 1.43 |
| KCNb2 | 40.84 | 27.37 | 41.29 | 24.44 | 600 | 20.68 | 12.5 | 23.9 | 28.7 | 0.76 | 0.43 | 0.51 | 1.20 |
| KANc1 | 35.48 | 27.05 | 38.99 | 29.37 | 795 | 14.78 | 11.3 | 16.5 | 35.7 | 1.03 | 0.30 | 0.64 | 2.16 |
| KBNc1 | 41.53 | 31.45 | 43.41 | 31.05 | 797 | 24.74 | 12.2 | 19.2 | 42.8 | 0.92 | 0.34 | 0.77 | 2.23 |
| KCNc1 | 44.32 | 30.86 | 44.24 | 27.64 | 796 | 33.83 | 12.5 | 19.6 | 42.6 | 0.92 | 0.35 | 0.76 | 2.17 |
| KANc2 | 33.56 | 26.58 | 36.60 | 29.52 | 799 | 5.80 | 11.6 | 15.4 | 17.6 | 1.11 | 0.28 | 0.31 | 1.14 |
| KBNc2 | 38.57 | 30.92 | 41.39 | 33.29 | 798 | 9.47 | 10.8 | 18.1 | 22.7 | 0.97 | 0.32 | 0.41 | 1.25 |
| KCNc2 | 42.91 | 35.39 | 44.00 | 34.37 | 799 | 11.02 | 11.3 | 20.5 | 23.8 | 0.86 | 0.37 | 0.43 | 1.16 |
| KAWa1 | 36.42 | 28.45 | 37.52 | 29.13 | 397 | 18.75 | 49.5 | 23.7 | 46.2 | 0.53 | 0.58 | 1.13 | 1.95 |
| KBWa1 | 41.87 | 32.20 | 42.11 | 31.55 | 401 | 22.23 | 51.8 | 25.9 | 39.5 | 0.47 | 0.63 | 0.96 | 1.52 |
| KCWa1 | 44.12 | 31.60 | 44.73 | 31.05 | 399 | 29.87 | 43.7 | 26.5 | 40.1 | 0.46 | 0.65 | 0.98 | 1.51 |
| KAWa2 | 39.21 | 31.31 | 40.40 | 32.60 | 394 | 21.55 | 55.3 | 25.3 | 49.3 | 0.49 | 0.62 | 1.20 | 1.95 |
| KBWa2 | 43.90 | 35.29 | 44.48 | 35.25 | 396 | 24.55 | 53.4 | 27.3 | 45.8 | 0.44 | 0.67 | 1.12 | 1.68 |
| KCWa2 | 45.01 | 34.69 | 44.32 | 33.56 | 400 | 17.78 | 54.6 | 27.3 | 27.5 | 0.45 | 0.67 | 0.67 | 1.01 |
| KAWb1 | 38.92 | 30.38 | 42.29 | 33.23 | 597 | 20.01 | 55.9 | 17.9 | 43.0 | 0.71 | 0.44 | 1.05 | 2.40 |
| KBWb1 | 44.12 | 34.41 | 45.25 | 34.20 | 597 | 25.13 | 84.0 | 19.9 | 42.0 | 0.65 | 0.49 | 1.02 | 2.11 |
| KCWb1 | 45.45 | 34.44 | 45.17 | 31.35 | 598 | 16.92 | 54.4 | 20.1 | 24.5 | 0.65 | 0.49 | 0.60 | 1.22 |
| KAWb2 | 33.69 | 25.98 | 35.16 | 26.18 | 596 | 10.14 | 70.4 | 15.4 | 28.1 | 0.84 | 0.38 | 0.68 | 1.82 |
| KBWb2 | 38.56 | 29.56 | 39.68 | 28.09 | 598 | 15.08 | 67.2 | 17.6 | 31.3 | 0.73 | 0.43 | 0.76 | 1.78 |
| KCWb2 | 40.24 | 28.93 | 41.05 | 28.45 | 598 | 20.10 | 57.5 | 17.7 | 32.7 | 0.74 | 0.43 | 0.80 | 1.85 |
| KAWc1 | 34.95 | 27.66 | 39.10 | 30.86 | 801 | 9.47 | 79.2 | 12.1 | 26.4 | 1.01 | 0.30 | 0.64 | 2.18 |
| KBWc1 | 41.26 | 32.59 | 42.78 | 33.25 | 800 | 9.95 | 81.3 | 14.1 | 19.8 | 0.92 | 0.34 | 0.48 | 1.41 |
| KCWc1 | 42.40 | 31.34 | 42.66 | 31.27 | 799 | 9.47 | 84.0 | 13.9 | 14.8 | 0.96 | 0.34 | 0.36 | 1.06 |
| KAWc2 | 36.28 | 26.96 | 38.08 | 28.18 | 802 | 14.40 | 77.6 | 11.9 | 31.1 | 1.07 | 0.29 | 0.76 | 2.62 |
| KBWc2 | 40.54 | 30.48 | 41.95 | 31.27 | 796 | 20.98 | 72.6 | 13.6 | 37.4 | 0.96 | 0.33 | 0.91 | 2.76 |
| KCWc2 | 41.08 | 29.68 | 41.52 | 26.30 | 804 | 22.43 | 64.5 | 13.5 | 35.4 | 0.96 | 0.33 | 0.86 | 2.63 |

Note: $p_c/\gamma_M = 56 \text{ N/mm}^2$ with $\gamma_M=1.0$ for natural condition

$p_c/\gamma_M = 41 \text{ N/mm}^2$ with $\gamma_M=1.0$ for wet condition

Natural average = 1.63

Wet average = 1.86

Table 3.2 Details of test series for Mao Jue

| Specimen | D ₁ (mm) | d ₁ (mm) | D ₂ (mm) | d ₂ (mm) | L (mm) | P _{test} (kN) | m.c. (%) | $p_{c,c}$ (N/mm ²) | $p_{c,t}$ (N/mm ²) | $\bar{\lambda}$ | $\bar{\psi}_C$ | $\bar{\psi}_T$ | MF |
|----------|------------------------|------------------------|------------------------|------------------------|-----------|---------------------------|-------------|-----------------------------------|-----------------------------------|-----------------|----------------|----------------|------|
| MANa1 | 46.04 | 35.81 | 52.57 | 40.58 | 1000 | 27.64 | 14.2 | 17.5 | 42.0 | 1.11 | 0.38 | 0.91 | 2.41 |
| MBNa1 | 76.65 | 62.29 | 81.96 | 66.64 | 1004 | 60.19 | 14.3 | 27.9 | 38.4 | 0.71 | 0.61 | 0.84 | 1.38 |
| MCNa1 | 85.97 | 69.80 | 87.46 | 70.87 | 999 | 64.28 | 14.8 | 29.9 | 32.5 | 0.67 | 0.65 | 0.71 | 1.09 |
| MANa2 | 77.84 | 64.50 | 83.71 | 69.09 | 1000 | 43.59 | 14.4 | 28.5 | 29.2 | 0.69 | 0.62 | 0.64 | 1.03 |
| MBNa2 | 60.61 | 48.30 | 67.14 | 53.74 | 1001 | 37.60 | 14.3 | 23.0 | 35.7 | 0.87 | 0.50 | 0.78 | 1.55 |
| MCNa2 | 83.23 | 67.85 | 86.76 | 69.53 | 1002 | 54.81 | 12.0 | 29.5 | 30.0 | 0.66 | 0.64 | 0.65 | 1.02 |
| MANb1 | 63.76 | 52.35 | 73.98 | 60.83 | 1499 | 27.06 | 13.8 | 16.4 | 26.0 | 1.16 | 0.36 | 0.57 | 1.58 |
| MBNb1 | 77.24 | 63.98 | 90.47 | 75.74 | 1500 | 43.11 | 14.4 | 20.5 | 29.3 | 0.96 | 0.45 | 0.64 | 1.43 |
| MCNb1 | 95.19 | 77.24 | 103.05 | 83.10 | 1498 | 60.22 | 23.8 | 24.1 | 24.8 | 0.84 | 0.52 | 0.54 | 1.03 |
| MANb2 | 51.27 | 40.03 | 60.75 | 47.10 | 1498 | 18.08 | 14.0 | 12.4 | 22.4 | 1.43 | 0.27 | 0.49 | 1.81 |
| MBNb2 | 69.20 | 54.25 | 75.02 | 58.28 | 1497 | 42.43 | 18.0 | 16.9 | 29.3 | 1.17 | 0.37 | 0.64 | 1.74 |
| MCNb2 | 68.25 | 53.63 | 77.92 | 59.07 | 1501 | 39.53 | 15.7 | 17.5 | 28.2 | 1.10 | 0.38 | 0.61 | 1.61 |
| MANc1 | 59.75 | 48.55 | 71.23 | 57.52 | 2000 | 15.08 | 13.8 | 10.5 | 15.8 | 1.60 | 0.23 | 0.34 | 1.50 |
| MBNc1 | 77.53 | 62.72 | 85.99 | 68.37 | 2001 | 41.76 | 16.4 | 14.0 | 25.6 | 1.33 | 0.31 | 0.56 | 1.82 |
| MCNc1 | 73.22 | 58.04 | 86.45 | 68.43 | 2002 | 46.01 | 15.0 | 13.6 | 29.4 | 1.34 | 0.30 | 0.64 | 2.17 |
| MANc2 | 54.82 | 45.32 | 67.91 | 54.62 | 1997 | 9.38 | 14.7 | 10.1 | 12.6 | 1.61 | 0.22 | 0.27 | 1.24 |
| MBNc2 | 75.89 | 61.75 | 88.48 | 71.94 | 1999 | 25.03 | 13.9 | 14.3 | 16.4 | 1.30 | 0.31 | 0.36 | 1.15 |
| MCNc2 | 89.22 | 73.58 | 99.27 | 80.16 | 1999 | 37.31 | 13.9 | 17.1 | 18.7 | 1.14 | 0.37 | 0.41 | 1.09 |
| MAWa1 | 59.38 | 50.52 | 64.91 | 55.62 | 998 | 23.19 | 28.0 | 20.1 | 30.3 | 1.01 | 0.46 | 0.69 | 1.51 |
| MBWa1 | 74.03 | 60.31 | 81.62 | 66.23 | 998 | 48.53 | 33.1 | 24.8 | 33.5 | 0.81 | 0.56 | 0.76 | 1.35 |
| MCWa1 | 85.56 | 68.51 | 94.09 | 74.91 | 1001 | 79.07 | 24.0 | 27.6 | 38.3 | 0.71 | 0.63 | 0.87 | 1.39 |
| MAWa2 | 54.16 | 42.16 | 62.11 | 47.27 | 998 | 28.32 | 32.4 | 18.4 | 31.2 | 1.06 | 0.42 | 0.71 | 1.70 |
| MBWa2 | 65.18 | 52.21 | 71.50 | 56.69 | 998 | 42.33 | 32.1 | 21.9 | 35.4 | 0.93 | 0.50 | 0.81 | 1.62 |
| MCWa2 | 88.32 | 71.72 | 94.64 | 76.57 | 997 | 75.68 | 20.5 | 28.1 | 36.3 | 0.70 | 0.64 | 0.82 | 1.29 |
| MAWb1 | 57.86 | 46.20 | 67.39 | 55.12 | 1499 | 23.19 | 20.8 | 11.8 | 24.3 | 1.51 | 0.27 | 0.55 | 2.07 |
| MBWb1 | 70.90 | 58.54 | 78.95 | 65.16 | 1498 | 34.79 | 27.6 | 15.4 | 27.7 | 1.25 | 0.35 | 0.63 | 1.80 |
| MCWb1 | 75.30 | 60.45 | 86.69 | 67.51 | 1501 | 64.86 | 22.0 | 17.2 | 41.0 | 1.12 | 0.39 | 0.93 | 2.39 |
| MAWb2 | 70.27 | 56.29 | 77.37 | 62.13 | 1499 | 33.93 | 34.0 | 14.8 | 24.4 | 1.30 | 0.34 | 0.56 | 1.65 |
| MBWb2 | 60.18 | 47.41 | 69.54 | 54.70 | 1498 | 22.71 | 58.7 | 12.5 | 21.0 | 1.44 | 0.29 | 0.48 | 1.68 |
| MCWb2 | 75.80 | 61.09 | 82.79 | 64.79 | 1500 | 35.67 | 38.8 | 16.5 | 22.6 | 1.18 | 0.38 | 0.51 | 1.36 |
| MAWc1 | 42.64 | 32.47 | 58.92 | 45.95 | 1999 | 10.14 | 18.5 | 6.0 | 16.9 | 2.22 | 0.14 | 0.38 | 2.82 |
| MBWc1 | 72.68 | 59.00 | 84.76 | 67.81 | 1998 | 21.46 | 27.9 | 11.3 | 15.2 | 1.53 | 0.26 | 0.35 | 1.34 |
| MCWc1 | 69.26 | 55.56 | 83.38 | 66.67 | 2000 | 25.84 | 20.1 | 10.8 | 19.2 | 1.57 | 0.25 | 0.44 | 1.78 |
| MAWc2 | 53.31 | 42.73 | 68.09 | 54.42 | 1998 | 8.12 | 22.8 | 7.9 | 10.2 | 1.89 | 0.18 | 0.23 | 1.29 |
| MBWc2 | 63.85 | 50.01 | 78.68 | 62.40 | 1999 | 19.62 | 22.4 | 9.6 | 15.9 | 1.69 | 0.22 | 0.36 | 1.65 |
| MCWc2 | 79.73 | 63.24 | 92.90 | 71.71 | 2001 | 31.61 | 22.5 | 12.8 | 17.1 | 1.41 | 0.29 | 0.39 | 1.34 |

Note: $p_c/\gamma_M = 46 \text{ N/mm}^2$ with $\gamma_M=1.0$ for natural condition

$p_c/\gamma_M = 44 \text{ N/mm}^2$ with $\gamma_M=1.0$ for wet condition

Natural average = 1.48

Wet average = 1.67

Table 3.3 Non-prismatic parameter α for column buckling of Mao Jue

| ρ | α |
|--------|----------|
| 0.00 | 1.000 |
| 0.05 | 1.025 |
| 0.10 | 1.050 |
| 0.15 | 1.074 |
| 0.20 | 1.098 |
| 0.25 | 1.123 |
| 0.30 | 1.147 |
| 0.35 | 1.170 |
| 0.40 | 1.194 |
| 0.45 | 1.218 |
| 0.50 | 1.241 |
| 0.55 | 1.265 |
| 0.60 | 1.288 |
| 0.65 | 1.311 |
| 0.70 | 1.334 |
| 0.75 | 1.357 |
| 0.80 | 1.380 |
| 0.85 | 1.403 |
| 0.90 | 1.425 |
| 0.95 | 1.448 |
| 1.00 | 1.471 |
| 1.05 | 1.493 |
| 1.10 | 1.516 |
| 1.15 | 1.538 |
| 1.20 | 1.560 |
| 1.25 | 1.582 |
| 1.30 | 1.605 |
| 1.35 | 1.627 |
| 1.40 | 1.649 |
| 1.45 | 1.671 |
| 1.50 | 1.693 |

| ρ | α |
|--------|----------|
| 1.50 | 1.693 |
| 1.55 | 1.715 |
| 1.60 | 1.736 |
| 1.65 | 1.758 |
| 1.70 | 1.780 |
| 1.75 | 1.802 |
| 1.80 | 1.823 |
| 1.85 | 1.845 |
| 1.90 | 1.867 |
| 1.95 | 1.888 |
| 2.00 | 1.910 |
| 2.05 | 1.931 |
| 2.10 | 1.953 |
| 2.15 | 1.974 |
| 2.20 | 1.996 |
| 2.25 | 2.017 |
| 2.30 | 2.038 |
| 2.35 | 2.060 |
| 2.40 | 2.081 |
| 2.45 | 2.102 |
| 2.50 | 2.123 |
| 2.55 | 2.145 |
| 2.60 | 2.166 |
| 2.65 | 2.187 |
| 2.70 | 2.208 |
| 2.75 | 2.229 |
| 2.80 | 2.250 |
| 2.85 | 2.271 |
| 2.90 | 2.292 |
| 2.95 | 2.313 |
| 3.00 | 2.334 |

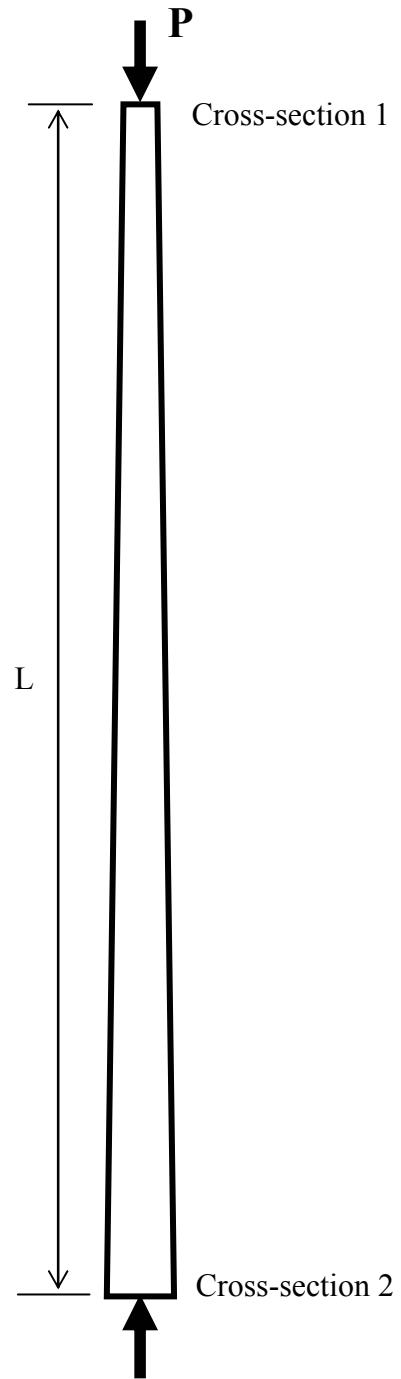

Table 3.4 Strength reduction factor $\bar{\psi}_c$

| $\bar{\lambda}$ | a | | | | | | |
|-----------------|----------|-----------|-----------|-----------|-----------|-----------|-----------|
| | 8 | 12 | 15 | 16 | 20 | 24 | 28 |
| 0.20 | 1.000 | 1.000 | 1.000 | 1.000 | 0.999 | 0.999 | 0.999 |
| 0.25 | 0.976 | 0.964 | 0.956 | 0.953 | 0.942 | 0.931 | 0.920 |
| 0.30 | 0.952 | 0.929 | 0.913 | 0.908 | 0.888 | 0.869 | 0.850 |
| 0.35 | 0.927 | 0.895 | 0.873 | 0.865 | 0.838 | 0.812 | 0.788 |
| 0.40 | 0.902 | 0.861 | 0.833 | 0.824 | 0.790 | 0.760 | 0.731 |
| 0.45 | 0.877 | 0.827 | 0.794 | 0.784 | 0.746 | 0.711 | 0.680 |
| 0.50 | 0.850 | 0.794 | 0.757 | 0.745 | 0.703 | 0.667 | 0.634 |
| 0.55 | 0.822 | 0.760 | 0.720 | 0.708 | 0.664 | 0.625 | 0.591 |
| 0.60 | 0.794 | 0.727 | 0.684 | 0.672 | 0.626 | 0.587 | 0.553 |
| 0.65 | 0.764 | 0.693 | 0.650 | 0.637 | 0.590 | 0.551 | 0.517 |
| 0.70 | 0.734 | 0.661 | 0.616 | 0.603 | 0.557 | 0.518 | 0.485 |
| 0.75 | 0.703 | 0.628 | 0.584 | 0.571 | 0.525 | 0.487 | 0.455 |
| 0.80 | 0.672 | 0.597 | 0.553 | 0.540 | 0.496 | 0.459 | 0.428 |
| 0.85 | 0.640 | 0.566 | 0.524 | 0.511 | 0.468 | 0.432 | 0.402 |
| 0.90 | 0.609 | 0.537 | 0.496 | 0.484 | 0.442 | 0.408 | 0.379 |
| 0.95 | 0.578 | 0.509 | 0.469 | 0.458 | 0.418 | 0.385 | 0.358 |
| 1.00 | 0.549 | 0.482 | 0.444 | 0.433 | 0.395 | 0.364 | 0.338 |
| 1.05 | 0.520 | 0.456 | 0.420 | 0.410 | 0.374 | 0.344 | 0.320 |
| 1.10 | 0.492 | 0.432 | 0.398 | 0.388 | 0.354 | 0.326 | 0.303 |
| 1.15 | 0.465 | 0.409 | 0.377 | 0.368 | 0.336 | 0.309 | 0.287 |
| 1.20 | 0.440 | 0.388 | 0.358 | 0.349 | 0.318 | 0.293 | 0.273 |
| 1.25 | 0.417 | 0.368 | 0.339 | 0.331 | 0.302 | 0.279 | 0.259 |
| 1.30 | 0.394 | 0.349 | 0.322 | 0.314 | 0.287 | 0.265 | 0.246 |
| 1.35 | 0.373 | 0.331 | 0.306 | 0.299 | 0.273 | 0.252 | 0.235 |
| 1.40 | 0.354 | 0.314 | 0.291 | 0.284 | 0.260 | 0.240 | 0.224 |
| 1.45 | 0.336 | 0.299 | 0.277 | 0.271 | 0.248 | 0.229 | 0.214 |
| 1.50 | 0.318 | 0.284 | 0.264 | 0.258 | 0.237 | 0.219 | 0.204 |
| 1.55 | 0.302 | 0.271 | 0.252 | 0.246 | 0.226 | 0.209 | 0.195 |
| 1.60 | 0.288 | 0.258 | 0.240 | 0.235 | 0.216 | 0.200 | 0.187 |
| 1.65 | 0.274 | 0.246 | 0.229 | 0.224 | 0.206 | 0.192 | 0.179 |
| 1.70 | 0.261 | 0.235 | 0.219 | 0.214 | 0.198 | 0.184 | 0.172 |
| 1.75 | 0.248 | 0.224 | 0.210 | 0.205 | 0.189 | 0.176 | 0.165 |
| 1.80 | 0.237 | 0.214 | 0.201 | 0.196 | 0.181 | 0.169 | 0.158 |
| 1.85 | 0.226 | 0.205 | 0.192 | 0.188 | 0.174 | 0.162 | 0.152 |
| 1.90 | 0.216 | 0.196 | 0.184 | 0.180 | 0.167 | 0.156 | 0.146 |
| 1.95 | 0.207 | 0.188 | 0.177 | 0.173 | 0.161 | 0.150 | 0.141 |
| 2.00 | 0.198 | 0.181 | 0.170 | 0.166 | 0.154 | 0.144 | 0.135 |
| 2.05 | 0.190 | 0.173 | 0.163 | 0.160 | 0.149 | 0.139 | 0.131 |
| 2.10 | 0.182 | 0.166 | 0.157 | 0.154 | 0.143 | 0.134 | 0.126 |
| 2.15 | 0.174 | 0.160 | 0.151 | 0.148 | 0.138 | 0.129 | 0.122 |
| 2.20 | 0.168 | 0.154 | 0.145 | 0.143 | 0.133 | 0.125 | 0.117 |
| 2.25 | 0.161 | 0.148 | 0.140 | 0.137 | 0.128 | 0.120 | 0.113 |
| 2.30 | 0.155 | 0.143 | 0.135 | 0.133 | 0.124 | 0.116 | 0.110 |
| 2.35 | 0.149 | 0.138 | 0.130 | 0.128 | 0.120 | 0.112 | 0.106 |
| 2.40 | 0.144 | 0.133 | 0.126 | 0.123 | 0.116 | 0.109 | 0.103 |
| 2.45 | 0.138 | 0.128 | 0.121 | 0.119 | 0.112 | 0.105 | 0.099 |
| 2.50 | 0.133 | 0.124 | 0.117 | 0.115 | 0.108 | 0.102 | 0.096 |

4. Connections

4.1 Introduction

This Chapter presents an experimental investigation on the resistances of the beam-column connections in bamboo scaffolds where the connections are formed using either bamboo strips or plastic strips. After statistical analysis, the characteristic connection resistances of the beam-column connections and the column splices with Kao Jue and Mao Jue are presented for practical design.

4.2 Beam-column connection tests

Due to the variations in the diameters of both Kao Jue and Mao Jue, the ledger-post connections are practically formed with bamboo strips and plastic strips. It is commonly known that the connection resistances depend primarily on the workmanship of the scaffolding practitioners.

In order to assess the connection resistances in bamboo scaffolds, two test series were performed to assess the load capacities of typical beam-column connections using both bamboo strips and plastic strips. The tests were carried out for connections with three member configurations, and the test specimens are designated as follows:

$$J \left\{ \begin{array}{l} K \\ M \\ KM \end{array} \right\} \left\{ \begin{array}{l} B \\ C \end{array} \right\} \left\{ \begin{array}{l} -1 \\ -2 \\ -3 \\ \vdots \end{array} \right\}$$

where J denotes beam-column connection tests
 K denotes Kao Jue is used in both the beam and the column members
 M denotes Mao Jue is used in both the beam and the column members
 KM denotes Kao Jue and Mao Jue are used in the beam and the column members respectively
 B denotes bamboo strips
 C denotes plastic strips

Details of the tests are summarized in Tables 4.1 and 4.2. All the beam-column connections are fastened with either bamboo or plastic strips of 5 round turns. A plastic strip is also provided from the top of the column member to either the left-hand side or the right-hand side of the beam member in order to maintain the configuration before and during testing.

Typical test setup is shown in Figure 4.1. In the tests, the vertical member was hold in position and the loading was applied vertically to the horizontal member. Both the applied load and the vertical displacement were recorded during test. Typical load-deflection curves of the beam-column connections are presented in Figures 4.2 and 4.3.

4.3 Typical modes of failure

It is found that as the stiffnesses of both bamboo strips and plastic strips are limited, large deformation occurs in the strips under loading, and thus slipping between bamboo members may be critical, as shown in Figure 4.4. Moreover, splitting of both bamboo strips and bamboo strips may occur in some cases, as shown in Figure 4.5.

4.4 Tests results

Due to the apparent variation of the connection resistances, the characteristic resistances at fifth percentile should be adopted for design. After data analysis and statistical interpretation, the characteristic resistances of the connections in bamboo scaffolds are summarized in Tables 4.3 and 4.4. It should be noted that the presence of nodes in these connections often increase the connection resistances significantly.

It is found that for beam-column connections using both bamboo strips and plastic strips, the basic characteristic connection resistances with various member configurations are found to range from 1.10 kN to 1.24 kN. Moreover, the connection resistances using both bamboo strips and plastic strips are roughly the same. In the presence of nodes, the characteristic connection resistances are found to increase significantly for some cases, up to a value of 2.51 kN.

However, as there is little control on the provision of nodes in ledger-post connections on site, the basic connection resistance of each fastening should be taken as 1.10 kN. For simplicity, the basic connection resistances of each fastening in column splice for both Kao Jue and Mao Jue are also taken as 1.10 kN.

4.5 Conclusions

A total of 31 ledger-post connections with both Kao Jue and Mao Jue using bamboo strips and plastic strips were executed. Due to apparent variations in the measured connection resistances, the characteristic resistances at fifth percentile should be adopted for design.

For simplicity, the basic characteristic resistances of each fastening for all connections with Kao Jue and Mao Jue using either bamboo strips or plastic strips should be taken as 1.10 kN.

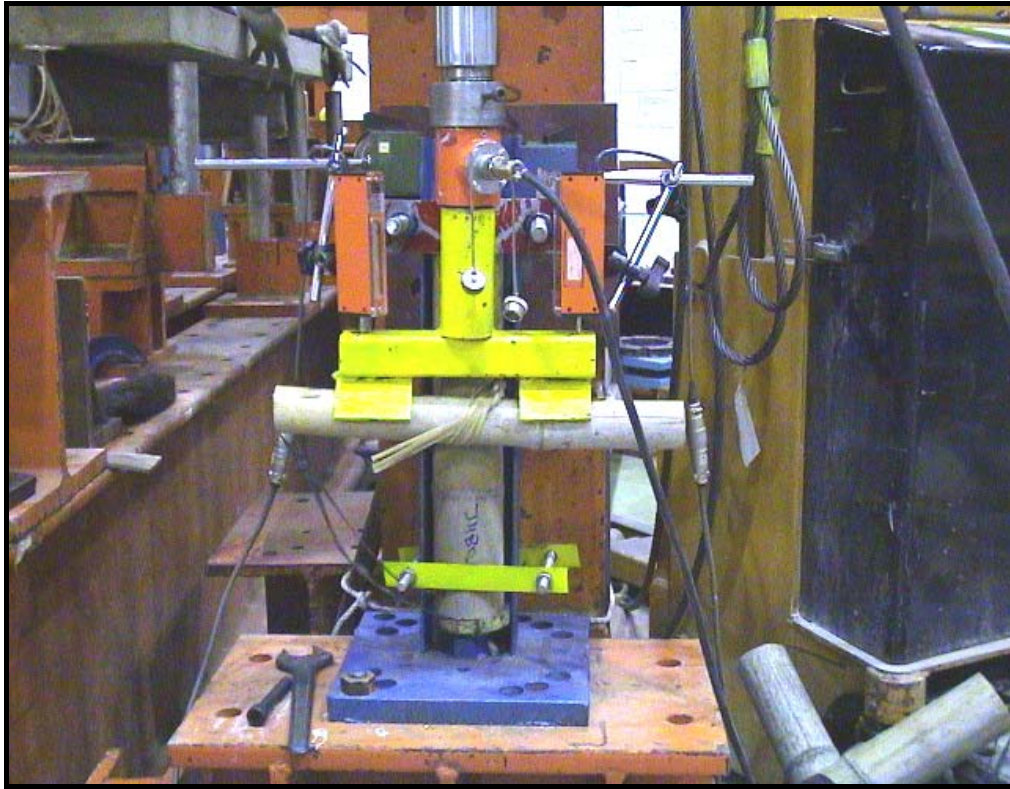

Figure 4.1 Typical setup of beam-column connection tests

Figure 4.2 Typical load deflection curves for ledger-post connections using bamboo strips

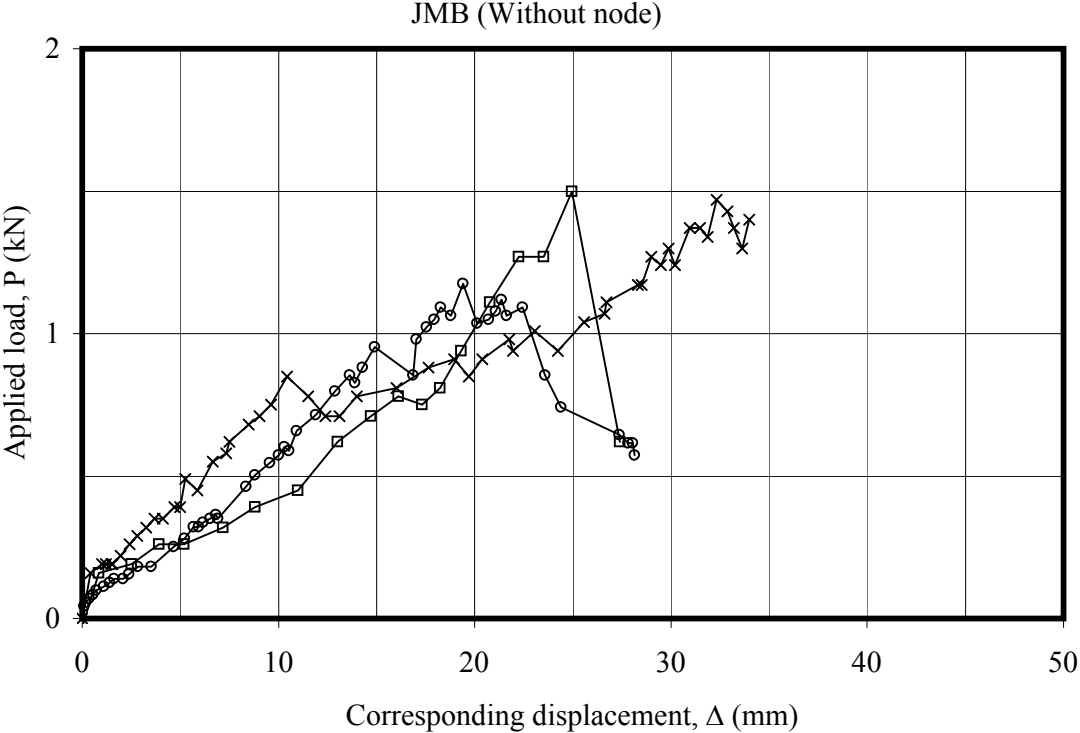

Figure 4.3 Typical load deflection curves for ledger-post connections using plastic strips

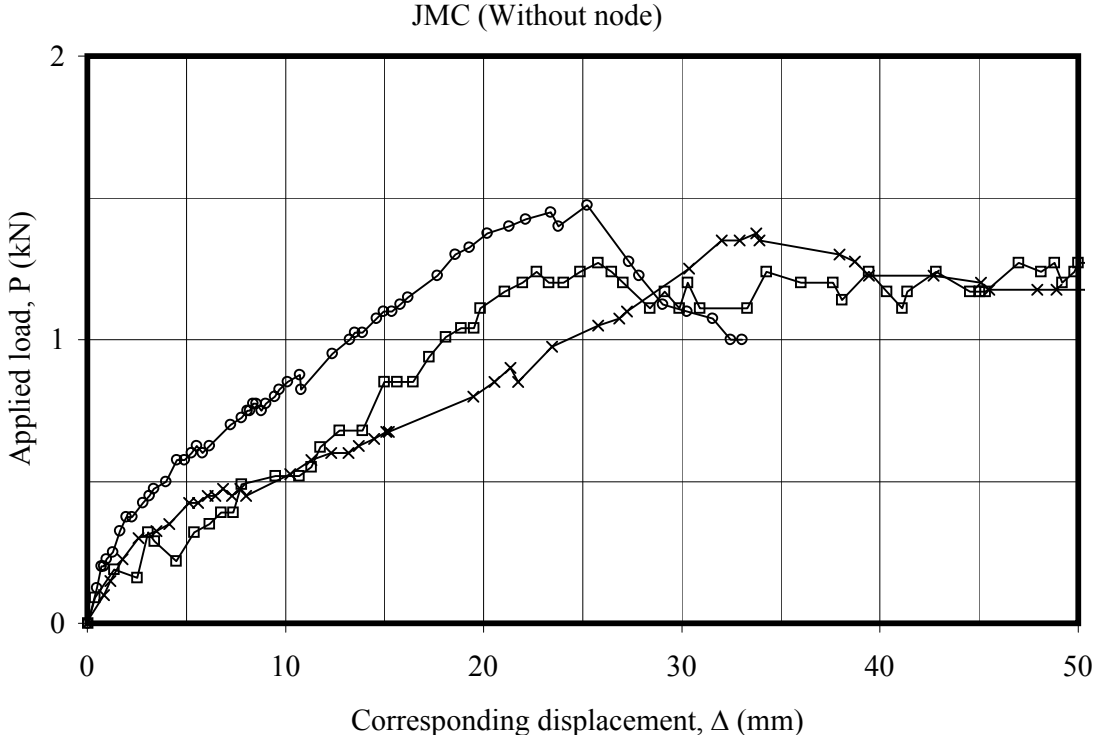



Figure 4.4 Slipping between members

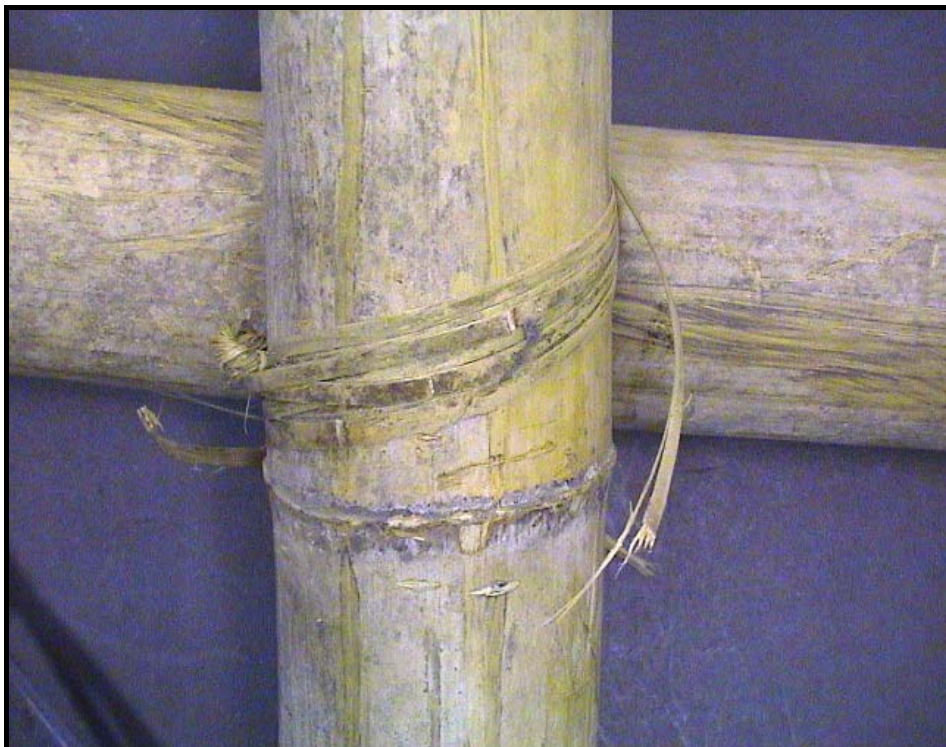

Figure 4.5 Strip splitting

Table 4.1 Test program for beam-column connections using bamboo strips



| Designation | Description | Typical configuration |
|-------------|---|---|
| JKB_1...4 | Beam-column connection with both Kao Jue |  |
| JMB_1...5 | Beam-column connection with both Mao Jue |  |
| JKMB_1...4 | Beam-column connection with Mao Jue and Kao Jue |  |

Table 4.2 Test program for beam-column connections using plastic strips



| Designation | Description | Typical configuration |
|-------------|---|---|
| JKC_1...5 | Beam-column connection with both Kao Jue |  |
| JMC_1...5 | Beam-column connection with both Mao Jue |  |
| JKMC_1...8 | Beam-column connection with Mao Jue and Kao Jue |  |

Table 4.3 Summary of structural performance of connections (without nodes)

| Test series | No. of tests | Connection resistance with plastic strips (kN) | No. of tests | Connection resistance with bamboo strips (kN) |
|-------------|--------------|--|--------------|---|
| JK | 2 | 1.10 | 3 | 1.19 |
| JM | 3 | 1.24 | 3 | 1.14 |
| JKM | 2 | 1.13 | 6 | 1.08 |

Table 4.4 Summary of structural performance of connections (with nodes)

| Test series | No. of tests | Connection resistance with plastic strips (kN) | No. of tests | Connection resistance with bamboo strips (kN) |
|-------------|--------------|--|--------------|---|
| JK | 2 | 2.51 | 2 | 1.16 |
| JM | 2 | 1.41 | 2 | 1.12 |
| JKM | 2 | 2.31 | 2 | 1.90 |

5. Structural forms of bamboo scaffolding systems

5.1 Introduction

This Chapter presents the basic configurations of typical bamboo scaffolds using both Kao Jue and Mao Jue, namely, the Single Layered Bamboo Scaffolds (SLBS) and the Double Layered Bamboo Scaffolds (DLBS). In order to provide guidance on the design of bamboo scaffolds with different practical arrangements of lateral restraints, a parametric study using advanced non-linear analysis on the structural behaviour of bamboo scaffolds are executed. Recommendations on the effective length coefficients for posts in both SLBS and DLBS with different practical arrangements of lateral restraints are also provided.

5.2 Common bamboo members in bamboo scaffolds

In South East Asia, in particular, in Hong Kong and the Southern China, both Kao Jue and Mao Jue are commonly used in bamboo scaffolds.

Kao Jue is a structural bamboo with a typical external diameter ranging from about 50 mm at the bottom to 30 mm at the top of a member over a typical length of 6 m. The wall thickness may range from 5 mm in low quality Kao Jue to 10 mm in high quality Kao Jue. They are used extensively as posts, standards (vertical members) and ledgers (horizontal members) in bamboo scaffolds.

Mao Jue is also a structural bamboo with a typical external diameter ranging from about 90 mm at the bottom to 60 mm at the top of a member over a typical length of 6 m. The wall thickness may range from 9 mm to 6 mm from the bottom to the top of the member. They are used extensively as posts (vertical members) and diagonal members in bamboo scaffolds.

Firs are heavy duty members in bamboo scaffolds, and they are used extensively as posts or vertical members.

5.3 Loading requirements

The loading requirements for general construction activities are given in Table 5.1 which is derived directly from the same requirements associated with metal scaffolds as given in BS5973^[33]. The construction loads and also the self-weight acting on bamboo scaffolds should not exceed the allowable loads permitted by the corresponding design. For typical applications as access scaffolding systems in building construction, the bamboo scaffolds are generally classified as ‘light duty’ scaffolds with a load allowance of 1.5 kPa. Moreover, wind effects on the scaffolds should be considered as appropriate.

5.4 Typical applications in construction

The applications of bamboo scaffolds in building construction are numerous while typical applications are:

- Single layered scaffolds
- Double layered scaffolds
- Demolition scaffolds
- Truss-out scaffolds
- Cantilever scaffolds (*or Signage scaffolds*)
- Platform scaffolds
- Foot-bridge scaffolds
- Civil engineering scaffolds

Details of typical applications are presented in the Erection Manual. As most of the scaffolds are generated from the basic scaffolding systems, namely, the Single Layered Bamboo Scaffolds (SLBS), and the Double Layered Bamboo Scaffolds (DLBS), only those two systems are discussed in details.

5.5 Basic configuration of SLBS

Figure 5.1 presents the configuration of the proposed SLBS systems; the member sizes are summarized in Table 5.2.

The usage of SLBS is to provide access for workers on site, and thus workers should not carry out any construction activity from the SLBS. The design is usually controlled by the own weight of the workers, i.e. 80 kg (unfactored) x 1.6 or 1.25 kN (factored). Typical height of the SLBS is about 6 to 9 m.

5.5.1 SLBS with Kao Jue

Figure 5.1a presents the configuration of the proposed SLBS systems using Kao Jue as follows:

Primary members

Both the main posts and the main ledgers are considered as primary structural members and carry construction loads; their structural performance should be checked in structural design. Typical configurations are as follows:

- Main posts at a spacing of 1.2 to 1.8 m in the horizontal direction, and
- Main ledgers at a spacing of 1.8 to 2.25 m in the vertical direction.

Bracing members

In order to enhance the structural behaviour of SLBS, additional members are also provided as bracing members as follows:

- Standards at a horizontal spacing of 0.6 m centres, i.e. one or two standards in between every two posts, and
- Ledgers at a vertical spacing of 0.6 to 0.75 m centres, i.e. two ledgers in between every two main ledgers.

In general, no supports may be provided to the standards due to site constraints, and the standards are attached to the base ledger. Additional Kao Jue is also installed as cross diagonals to increase the lateral stability of the structure. Moreover, additional ledgers are also provided to improve load distributions throughout the SLBS together with the standards and the diagonals. Some of the ledgers may be required to be load-bearing.

Supports

Lateral restraints are provided to the scaffolds at the post - main ledger connections, i.e. at the post spacing of 1.2 to 1.8 m in the horizontal direction and 1.8 to 2.25 m in the vertical direction. Due to site constraints, some lateral restraints may not be provided. In such cases, the load capacities of the scaffolds will be reduced significantly, and caution should be exercised in their usage. Refer to Chapter 1 for typical detail of lateral restraints.

Steel brackets are provided at the bottom of the posts as supports against gravity loading whenever necessary.

5.5.2 SLBS with Mao Jue

Figure 5.1b presents the configuration of the proposed SLBS systems using mainly Mao Jue as follows:

Primary members

Both the main posts and the main ledgers are considered as primary structural members and carry construction loads; their structural performance should be checked in structural design. Typical configurations are as follows:

- Main posts at a spacing of 1.5 to 2.4 m in the horizontal direction, and
- Main ledgers at a spacing of 1.8 to 2.25 m in the vertical direction.

Bracing members

In order to enhance the structural behaviour of SLBS, additional members are also provided as bracing members as follows:

- Standards at a horizontal spacing of 0.45 to 0.6 m centres, i.e. two to three standards in between every two posts, and
- Ledgers at a vertical spacing of 0.6 to 0.75 m centres, i.e. two ledgers in between every two main ledgers.

In general, no supports may be provided to the standards due to site constraints, and the standards are attached to the base ledger. Additional Mao Jue is also installed as

cross diagonals to increase the lateral stability of the structure. Moreover, additional ledgers are also provided to improve load distributions throughout the SLBS together with the standards and the diagonals. Some of the ledgers may be required to be load-bearing.

Supports

Lateral restraints are provided to the scaffolds at the post – main ledger connections, i.e. at the post spacing of 1.5 to 2.4 m in the horizontal direction and 1.8 to 2.25 m in the vertical direction. Due to site constraints, some lateral restraints may not be provided. In such cases, the load capacities of the scaffolds will be reduced significantly, and caution should be exercised in their usage. Refer to Chapter 1 for typical detail of lateral restraints.

Steel brackets are provided at the bottom of the posts as supports against gravity loading when necessary.

5.6 Basic configuration of DLBS

Figure 5.1c presents the configuration of the proposed DLBS Systems; the member sizes are also summarized in Table 5.2.

The usage of DLBS is to provide access and safe working platform to workers on site, and thus, the workers are allowed to carry out ‘light-duty’ construction activity from the DLBS. The design is usually controlled by the construction loads at a typical value of 1.5 kPa. Typical height of the DLBS is about 10 to 15 m.

5.6.1 Primary members

Outer layer

Mao Jue is used for both the posts and the base ledger together with Kao Jue as main ledgers as follows:

- Main posts at a spacing of 1.5 to 2.4 m in the horizontal direction, and
- Main ledgers at a spacing of 1.8 to 2.25 m in the vertical direction.

All main posts are supported at the bottom of the members.

Inner layer

Kao Jue is used for both the posts and the main ledgers as follows:

- Main posts at a spacing of 0.75 to 1.2 m in the horizontal direction, i.e. half of those in the outer layer, and
- Main ledgers at a spacing of 1.8 to 2.25 m in the vertical direction, i.e. same as those in the outer layer.

All main posts are supported at the bottom of the members.

5.6.2 Bracing members

Outer layer

Additional Kao Jue is also installed as follows:

- Three standards in between every two posts, i.e. at a horizontal spacing of 0.3 to 0.6 m centres.
- Ledgers at a vertical spacing of 0.6 to 0.75 m centres, i.e. two ledgers in between every two main ledgers.

In general, no supports may be provided to the standards due to site constraints, and the standards are attached to the base ledger instead. Additional Mao Jue is also installed as cross diagonals to increase the lateral stability of the structure. Moreover, additional ledgers are also provided to improve load distributions throughout the DLBS together with the standards and the diagonals. Some of the ledgers may be required to be load-bearing.

Inner layer

No bracing members are provided in the inner layer.

Linking outer and inner layers

In order to support construction loads from working platforms, Kao Jue is installed as transoms at the post - main ledger connections, i.e. at a spacing of 1.5 to 2.4 m in the horizontal direction and 1.8 to 2.25 m in the vertical direction. Additional transoms may also be provided along the main ledgers of both the outer and the inner layers. All construction loads acting onto the working platforms are applied through the transoms and the ledgers to the posts. Typical distance between the outer and the inner layers ranges from 600 to 750 mm.

5.6.3 Supports

Steel brackets are provided at the bottom of the bamboo scaffolds as supports to both the outer and the inner layers against gravity loading when necessary.

Lateral restraints are provided to the outer layer at a spacing of 1.5 to 2.4 m in the horizontal direction and 1.8 to 2.25 m in the vertical direction. Due to site constraints, some lateral restraints may not be provided. In such cases, the load capacities of the scaffolds will be reduced significantly, and caution should be exercised in their usage. Refer to Chapter 1 for typical detail of lateral restraints.

5.7 Arrangement of lateral restraints

In order to achieve overall structural stability of the bamboo scaffolds with high structural efficiency, lateral restraints should be provided at close intervals whenever feasible. However, due to site restrictions such as availability of strong supports in proximity, it may not be practical or even impossible to provide lateral restraints in every main post – main

ledger connection of the bamboo scaffolds. In the absence of sufficient lateral restraints, the effective length of bamboo columns will be larger than their member lengths between ledgers, reducing the axial buckling resistance of the bamboo columns significantly. Thus, it is necessary to provide design guidance on practical arrangements of lateral restraints.

An advanced non-linear finite element analysis using NIDA was carried out to investigate the column buckling behaviour of bamboo scaffolds based on high performance beam-column elements using the one-element-per-member formulation. Both SLBS and DLBS with various practical arrangements of lateral restraints are examined as follows:

- Typical distance between lateral restraints, H , is assigned to be 2.0 h, 2.667 h and 3.0 h in various arrangements where h is the height of a platform, or the vertical distance between two platforms.
- For each value of H , the lateral restraints are provided either at regular intervals or in a staggered manner.

The configurations of the systems are presented in Figures 5.2 to 5.4 while details of the member sizes may be found in Table 5.2.

Through advanced non-linear analysis, both the local buckling of bamboo posts between ledgers and the global instability of the entire structures with regular and staggered lateral restraints are accurately incorporated. In all cases, out-of-plane buckling of the posts is critical, and the deformed shapes of SLBS and DLBS are also presented in Figures 5.2 to 5.4. The predicted failure loads are the applied loads at first yield of the posts in the presence of initial geometrical imperfections under combined compression and bending.

It should be noted that for simplicity, diagonal members and secondary members such as standards and ledgers have not been included in the model. The lateral restraints provided in the model are sufficiently less than those in typical SLBS and DLBS, and consequently, the predicted load resistances of the posts are conservative. Table 5.3 summarizes the load resistances of the posts in SLBS and DLBS under various practical arrangements of lateral restraints. It should be noted that for simplicity, Mao Jue is modelled as a prismatic member with the external and the internal diameters at 60 and 48 mm respectively.

It should be noted that

- **SLBS**
The basic effective length of the posts, h_e , for SLBS with regular lateral restraints is found to range from 0.885 H to 0.956 H where H is the system length between lateral restraints. The reduction in the effective length depends on the member configurations of SLBS, and also the relative slenderness of the posts and the ledgers. Furthermore, for SLBS with staggered lateral restraints, the effective length, h_e , of the posts is found to range from 0.434 H to 0.561 H due to the restraining effects provided by the ledgers attached. Consequently, it is recommended that the effective length of a post, h_e , may conservatively be taken as as follows:

$$h_e = k_e \times H$$

where k_e is the effective length coefficient

- = 1.0 for SLBS with regular lateral restraints with $H = 1.0 h$ to $3.0 h$
- = 0.7 for SLBS with staggered lateral restraints with $H = 2.0 h$ to $3.0 h$
- H is the system length between lateral restraints
- h is the height of a platform, or the vertical distance between two platforms.

Based on the predicted structural performance of SLBS from the non-linear analysis, the maximum value of H should not exceed $3.0 h$ in practice.

- **DLBS**

It is found that due to the presence of bracing members in the posts of the outer layer, i.e. Mao Jue, it is always the posts of the inner layer, i.e. Kao Jue, that fails first. The basic effective length of Kao Jue, h_e , for DLBS with regular lateral restraints to the outer layer at $H = h$ is considered to be 1.0. For DLBS with regular lateral restraints to the outer layer at $H = 2.667 h$, the effective length of Kao Jue is found to be 1.460, i.e. an increase about 50%. Due to the restraining effects provided by the ledgers, the effective length of Kao Jue is found to be about 1.077, i.e. an increase about 10%, for DLBS with staggered lateral restraints to the outer layer at $H = 2.667 h$.

Consequently, it is recommended that the effective length of the post in DLBS, h_e , may conservatively be taken as as follows:

Inner layer

$$h_e = k_e \times h$$

where

k_e is the effective length coefficient

$$= k_i \times k_b$$

k_i = secondary effective length coefficient which depends on the restraint arrangement provided at the posts of the outer layer as follows:

| | | | | | |
|----------------------|-----|------|------|-------|------|
| H / h | 1.0 | 1.5 | 2.0 | 2.667 | 3.0 |
| k_i | 1.0 | 1.10 | 1.25 | 1.50 | 1.75 |

k_b = 1.0 for DLBS with regular lateral restraints, or

= 0.7 for DLBS with staggered lateral restraints

H is the system length between lateral restraints

h is the height of a platform, or the vertical distance between two platforms.

Outer layer

$$h_e = k_e \times H$$

where

k_e is the effective length coefficient

$$= k_o \times k_b$$

k_o = 0.7 for DLBS with $H = 1.0 h$ to $2.667 h$ to allow for the restraint effect provided by both ledgers and standards

k_b = 1.0 for DLBS with regular lateral restraints

= 0.7 for DLBS with staggered lateral restraints

H is the system length between lateral restraints

h is the height of a platform, or the vertical distance between two platforms.

Based on the predicted structural performance of DLBS from the non-linear analysis, the maximum value of H should not exceed $2.667 h$ in practice.

Figure 5.1 Typical configuration of SLBS and DLBS

a) SLBS using Kao Jue

$L = 1.2\text{m} \sim 1.8\text{m}$
 $h = 1.8\text{m} \sim 2.25\text{m}$

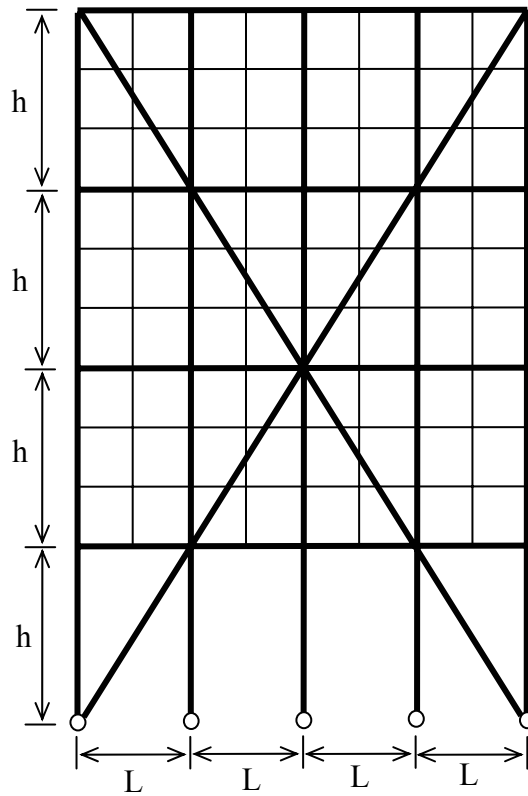

b) SLBS using Mao Jue

$L = 1.5\text{m} \sim 2.4\text{m}$
 $h = 1.8\text{m} \sim 2.25\text{m}$

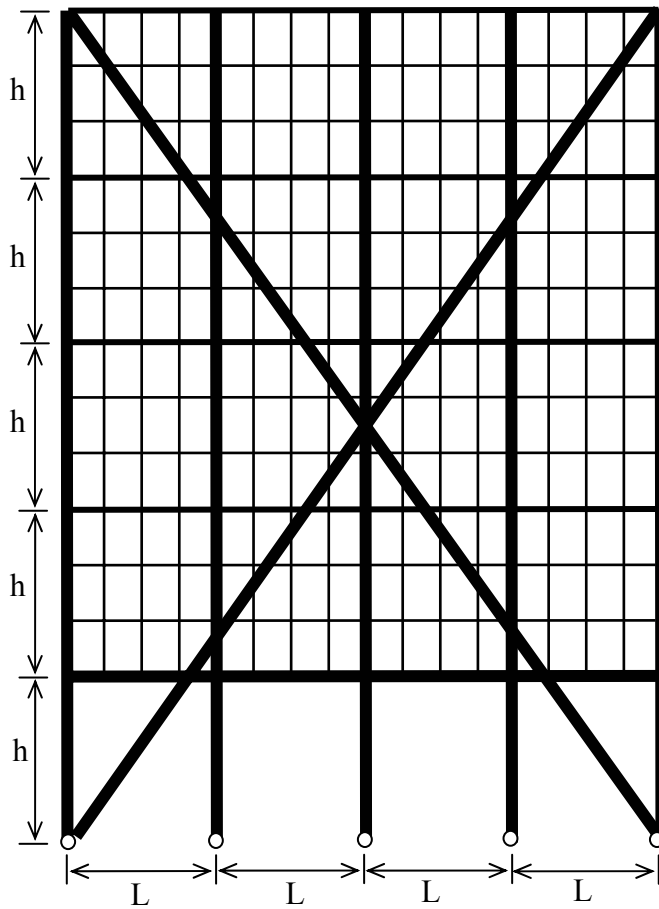
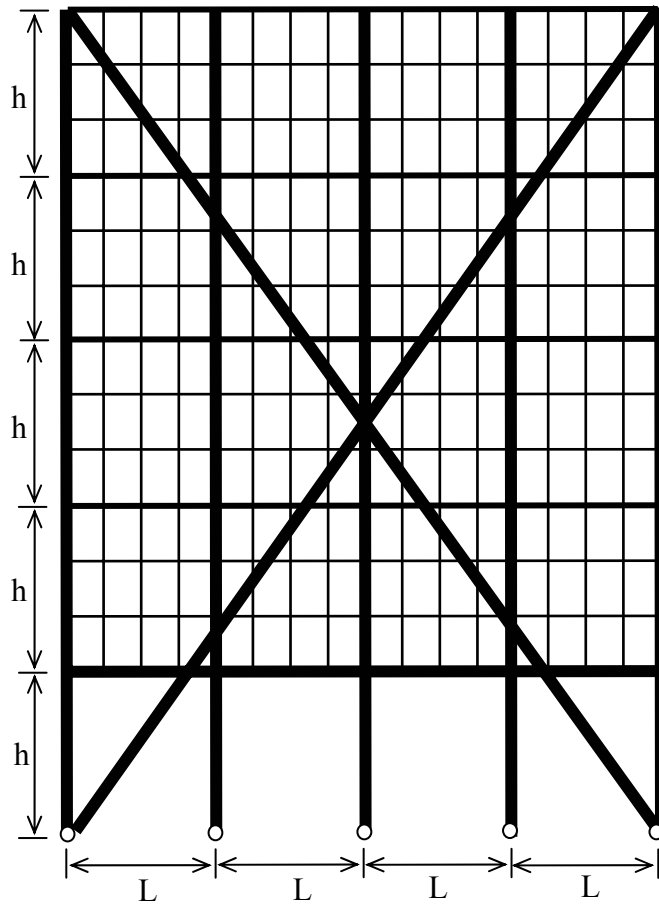

Figure 5.1 Typical configuration of SLBS and DLBS

c) DLBS with Mao Jue and Kao Jue

Outer layer

$L = 1.5\text{m} \sim 2.4\text{m}$
 $h = 1.8\text{m} \sim 2.25\text{m}$



Inner layer

$L = 1.5\text{m} \sim 2.4\text{m}$
 $h = 1.8\text{m} \sim 2.25\text{m}$

— lateral restraints connected to main posts of outer layer.

- - - lateral restraints connected to ledgers.

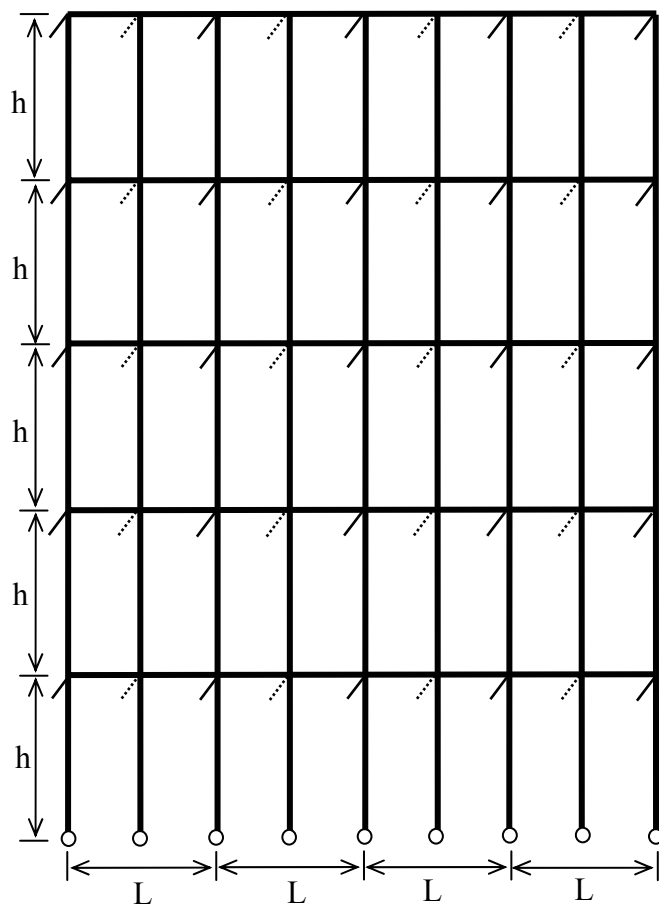
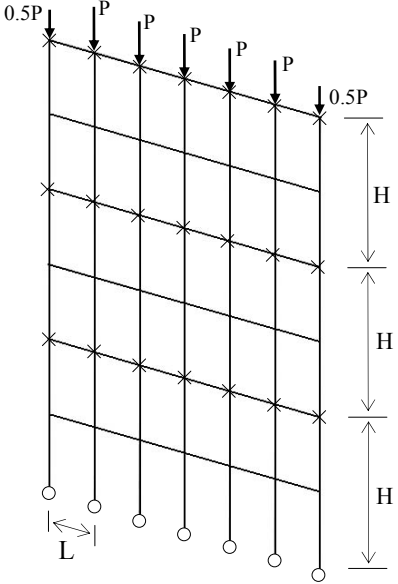
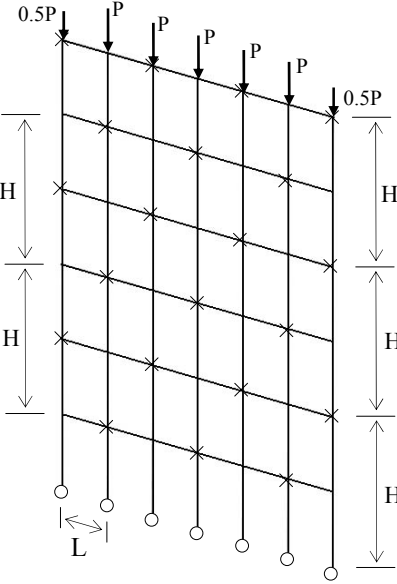
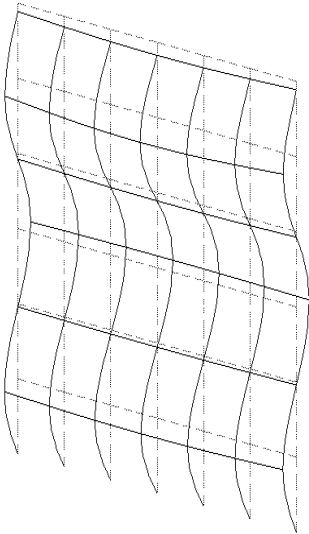
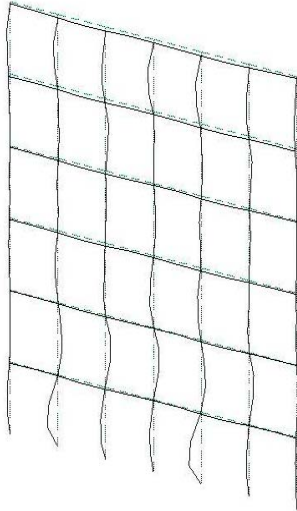

Figure 5.2a Results of SLBS with Kao Jue at H equal to 2 h

| Regular restraints | Staggered restraints |
|---|--|
|  |  |
|  |  |
| <p>$P = 0.776 \text{ kN}$ $k_e = 0.949$</p> | <p>$P = 2.655 \text{ kN}$ $k_e = 0.434$</p> |

Notes: Diagonals and bracing members are not included in analysis.

× – Lateral restraints

H = 2 h or 4000mm

$h_e = k_e H$

L = 1200 mm

Figure 5.2b Results of SLBS with Kao Jue at H equal to 2.667 h

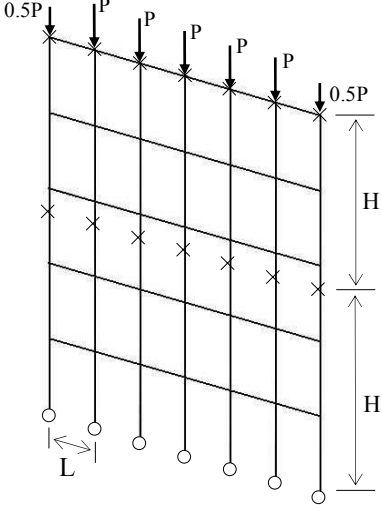
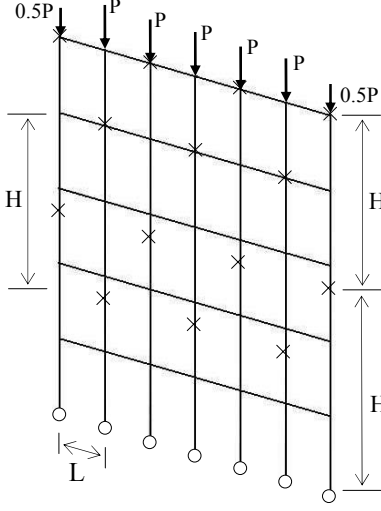
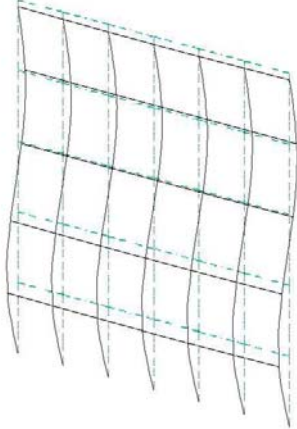
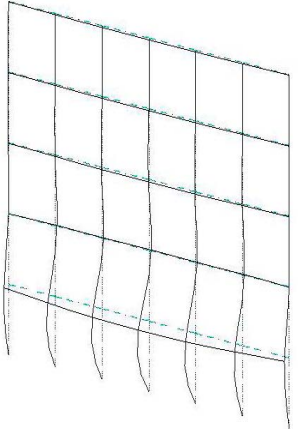
| Regular restraints | Staggered restraints |
|--|--|
|  |  |
|  |  |
| <p style="text-align: center;"> $P = 0.535 \text{ kN}$ $k_e = 0.885$ </p> | <p style="text-align: center;"> $P = 1.521 \text{ kN}$ $k_e = 0.471$ </p> |

Notes: Diagonals and bracing members are not included in analysis.

× – Lateral restraints

$H = 2.667 h$ or 5333 mm

$h_e = k_e H$

$L = 1200 \text{ mm}$

Figure 5.2c Results of SLBS with Kao Jue at H equal to 3 h

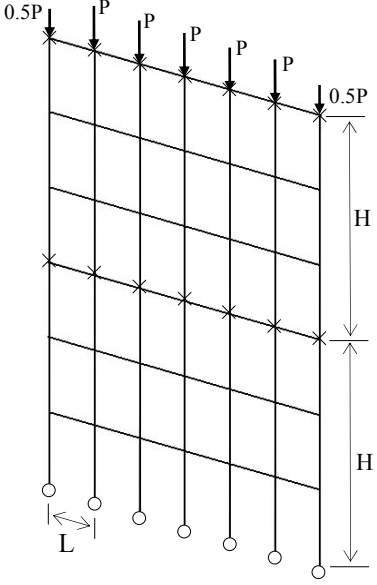
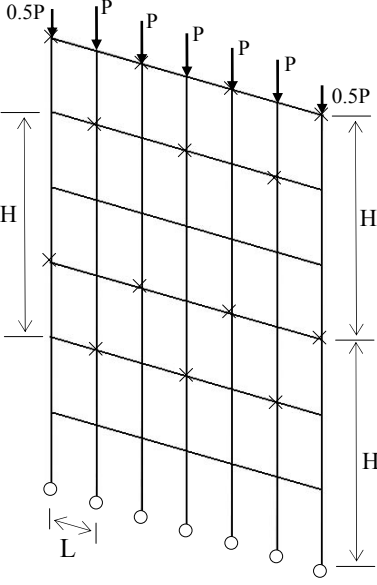
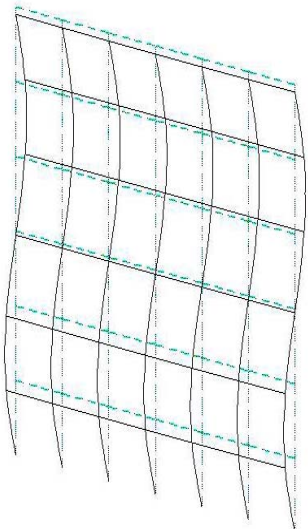
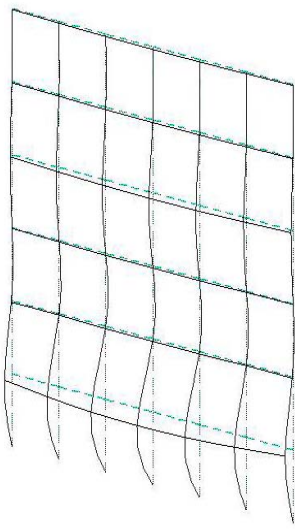
| Regular restraints | Staggered restraints |
|--|--|
|  |  |
|  |  |
| <p style="text-align: center;"> $P = 0.380 \text{ kN}$ $k_e = 0.956$ </p> | <p style="text-align: center;"> $P = 1.068 \text{ kN}$ $k_e = 0.522$ </p> |

Notes: Diagonals and bracing members are not included in analysis.

× – Lateral restraints

H = 3 h or 6000 mm

$h_e = k_e H$

L = 1200 mm

Figure 5.3a Results of SLBS with Mao Jue at H equal to 2 h

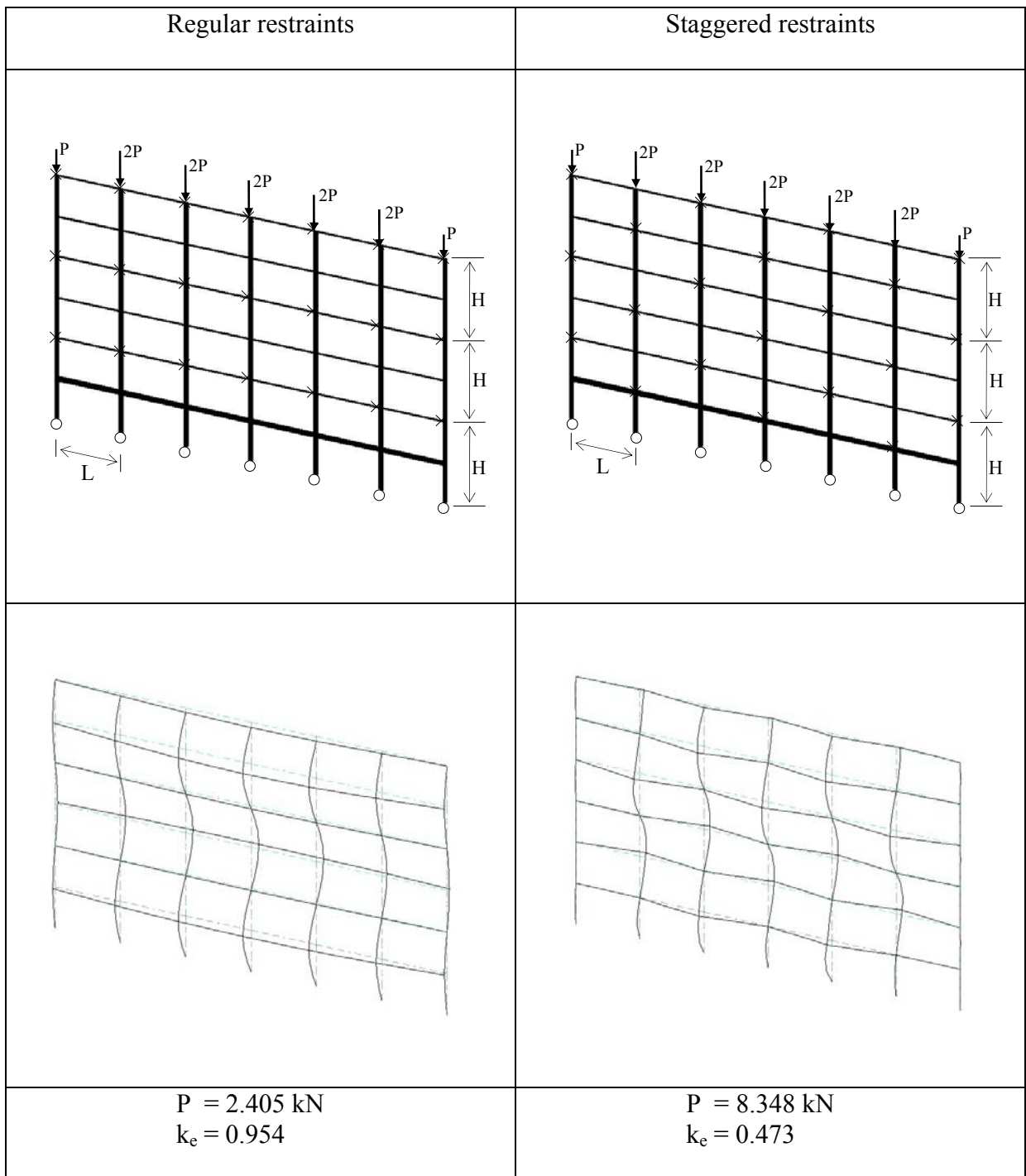

Notes: Diagonals and bracing members and also the inner layer are not included in analysis.

× – Lateral restraints

$H = 2 h$ or 4000 mm

$h_e = k_e H$

$L = 1800 \text{ mm}$

Figure 5.3b Results of SLBS with Mao Jue at H equal to 2.667 h

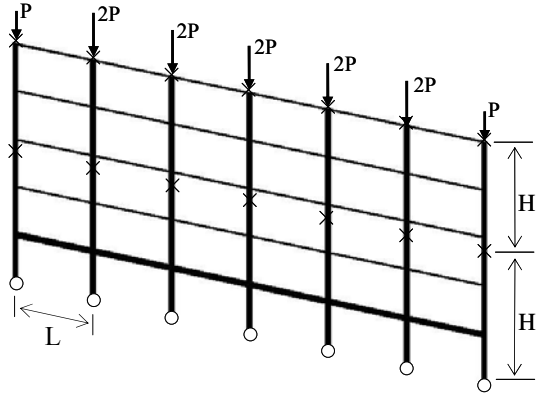
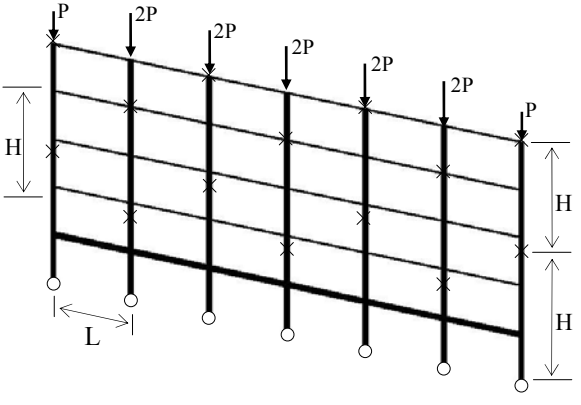
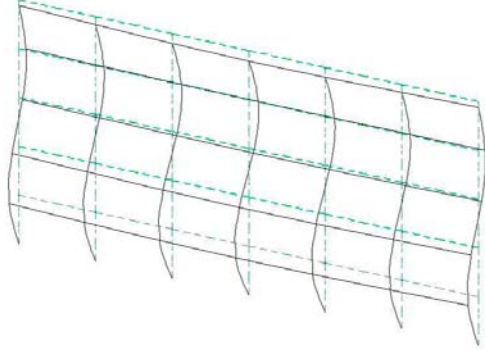
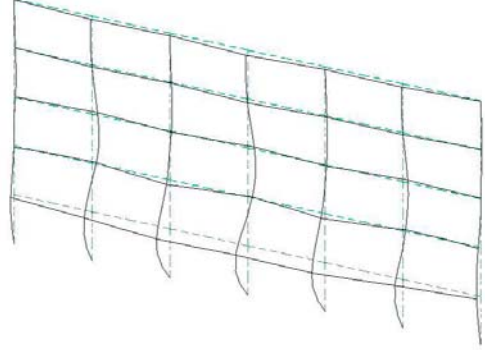
| Regular restraints | Staggered restraints |
|--|--|
|  |  |
|  |  |
| <p style="text-align: center;"> $P = 1.545 \text{ kN}$ $k_e = 0.907$ </p> | <p style="text-align: center;"> $P = 3.876 \text{ kN}$ $k_e = 0.551$ </p> |

Notes: Diagonals and bracing members and also the inner layer are not included in analysis.

× – Lateral restraints

H = 2.667 h or 5333 mm

$h_e = k_e H$

L = 1800 mm

Figure 5.3c Results of SLBS with Mao Jue at H equal to 3 h

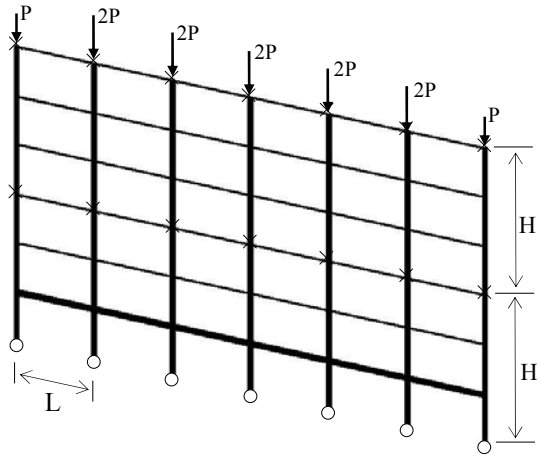
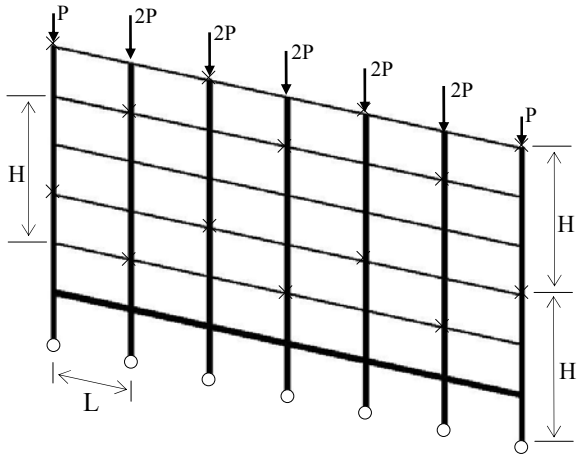
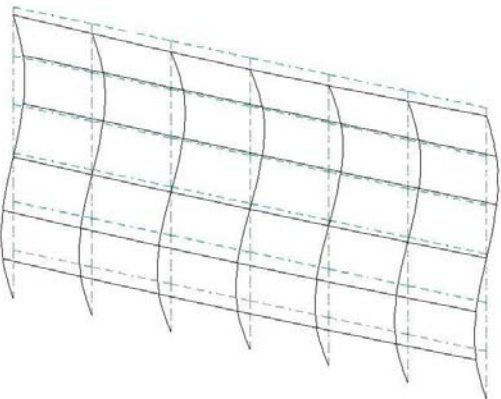
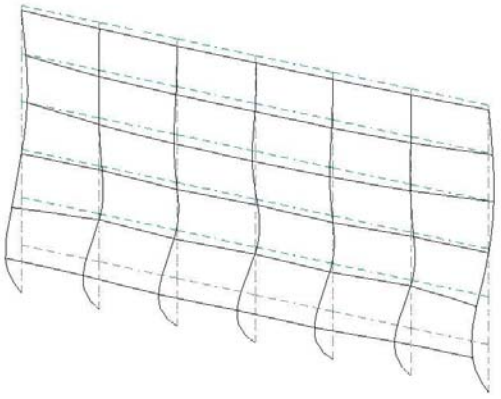
| Regular restraints | Staggered restraints |
|--|--|
|  |  |
|  |  |
| <p style="text-align: center;"> $P = 1.135 \text{ kN}$ $k_e = 0.949$ </p> | <p style="text-align: center;"> $P = 3.029 \text{ kN}$ $k_e = 0.561$ </p> |

Notes: Diagonals and bracing members and also the inner layer are not included in analysis.

× – Lateral restraints

H = 3 h or 6000 mm

$h_e = k_e H$

L = 1800 mm

Figure 5.4a Results of DLBS

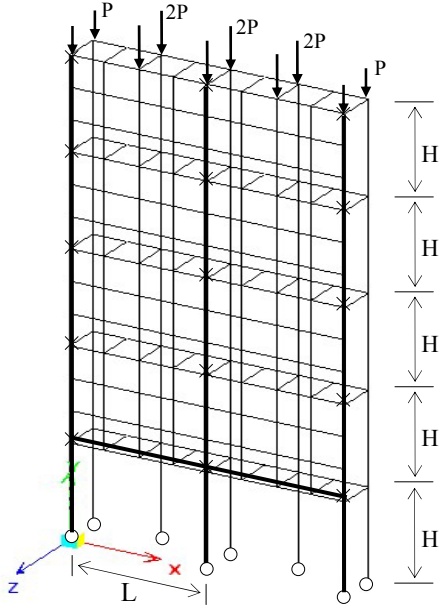
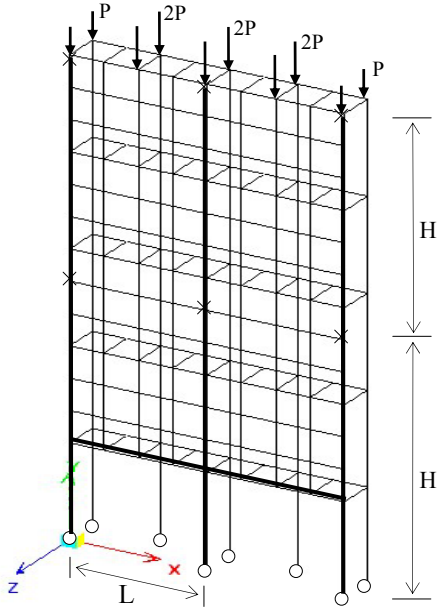
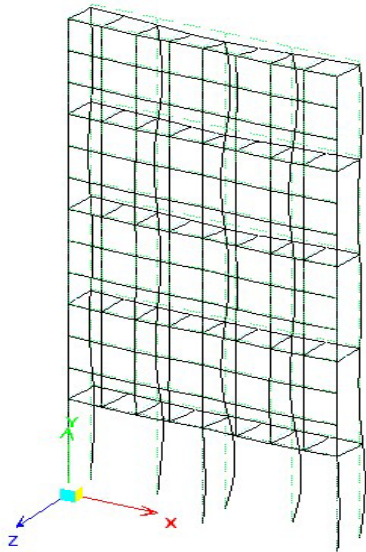
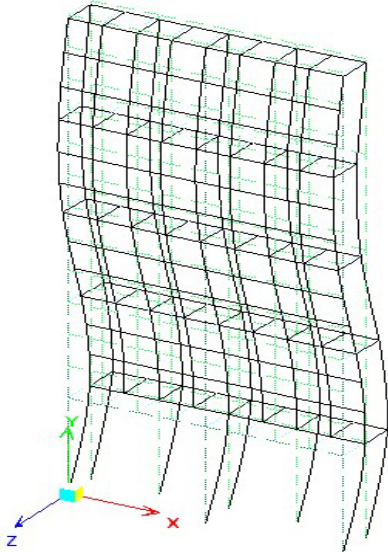
| H equal to h | H equal to 2.667 h with regular restraints |
|---|--|
|  |  |
|  |  |
| <p>$P = 2.156 \text{ kN}$ $k_e = 1.000$</p> | <p>$P = 1.196 \text{ kN}$ $k_e = 1.460$</p> |

Notes: Diagonals and bracing members are not included in analysis.

× – Lateral restraints

$h = 2000 \text{ mm}$

$h_e = k_e h$

$L = 2400 \text{ mm}$

Figure 5.4b Results of DLBS

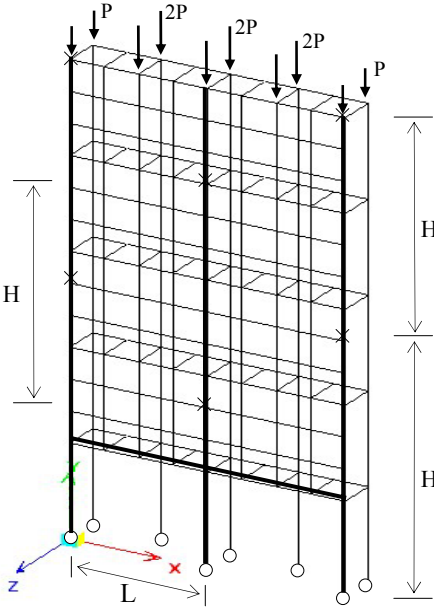
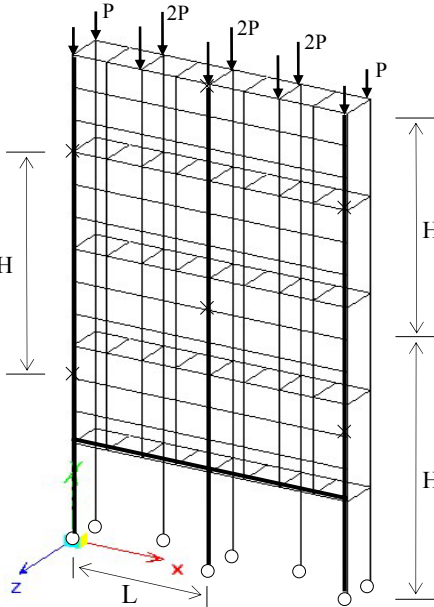
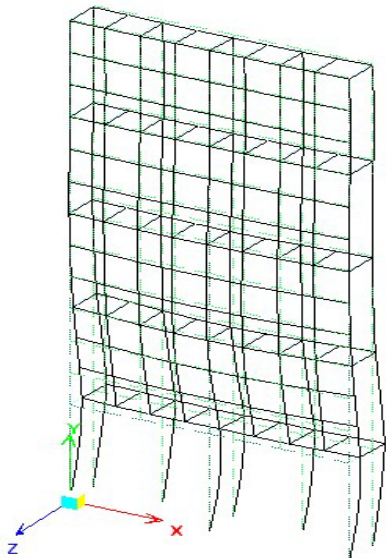
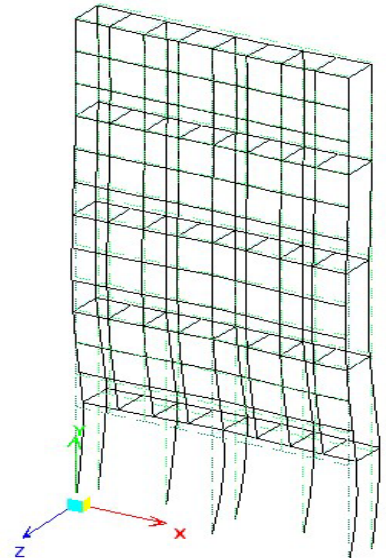
| <p>H equal to 2.667 h with staggered restraints – Pattern A</p> | <p>H equal to 2.667 h with staggered restraints– Pattern B</p> |
|---|--|
|  |  |
|  |  |
| <p>P = 1.929 kN k_e = 1.077</p> | <p>P = 1.936 kN k_e = 1.072</p> |

Notes: Diagonals and bracing members are not included in analysis.

× – Lateral restraints

h = 2000 mm

h_e = k_e h

L = 2400 mm

Table 5.1 General load requirements for bamboo scaffolds

| BS 5973: 1993: Table 1 Access and working scaffolds | | | | | |
|---|---|---|--|--|---------------------------|
| Duty | Use of platform | Distributed load on platforms (kN/m ²) | Maximum number of platforms | Commonly used widths using 225mm boards | Maximum bay length (m) |
| Inspection and very light duty | Inspection, painting, stone cleaning, light cleaning and access | 0.75 | 1 working platform | 3 boards | 2.7 |
| Light duty | Plastering, painting, stone cleaning, glazing and pointing | 1.50 | 2 working platforms | 4 boards | 2.4 |
| General purpose | General building work including brickwork, window and mullion fixing, rendering, plastering | 2.00 | 2 working platforms + 1 at very light duty | 5 boards or 4 boards + 1 inside | 2.1 |
| Heavy duty | Blockwork, brickwork, heavy cladding | 2.50 | 2 working platforms + 1 at very light duty | 5 boards or 5 boards + 1 inside or 4 boards + 1 inside | 2.0 |
| Masonry or special duty | Masonry work, concrete blockwork, and very heavy cladding | 3.00 | 1 working platform + 1 at very light duty | 6 to 8 boards | 1.8 |

Table 5.2 Material specifications for SLBS and DLBS

a) SLBS with Kao Jue

| Member | Member type | Member diameter (mm) |
|-------------|-------------|----------------------|
| Main post | Kao Jue | 40/30 |
| Base ledger | Kao Jue | 40/30 |
| Standard | Kao Jue | 40/30 |
| Ledger | Kao Jue | 40/30 |
| Diagonal | Kao Jue | 40/30 |

b) SLBS with Mao Jue

| Member | Member type | Member diameter (mm) |
|-------------|-------------|----------------------|
| Main post | Mao Jue | 60~90/48~72 |
| Base ledger | Mao Jue | 60~90/48~72 |
| Standard | Kao Jue | 40/30 |
| Ledger | Kao Jue | 40/30 |
| Diagonal | Mao Jue | 60~90/48~72 |

c) DLBS with Mao Jue and Kao Jue

| DLBS | Member type | Member diameter (mm) |
|-------------|-------------|----------------------|
| Outer layer | | |
| Main post | Mao Jue | 60~90/48~72 |
| Base ledger | Mao Jue | 60~90/48~72 |
| Standard | Kao Jue | 40/30 |
| Ledger | Kao Jue | 40/30 |
| Diagonal | Mao Jue | 60~90/48~72 |
| Transom | Kao Jue | 40/30 |
| Inner layer | | |
| Main post | Kao Jue | 40/30 |
| Base ledger | Kao Jue | 40/30 |
| Standard | Kao Jue | 40/30 |
| Ledger | Kao Jue | 40/30 |

Table 5.3 Load resistances and effective length coefficients of SLBS and DLBS derived from NIDA

a) SLBS with Kao Jue

| Distance between lateral restraints H (mm) | | Regular restraints | | | Staggered restraints | | |
|--|------|------------------------|------------------------|----------------|------------------------|------------------------|----------------|
| | | P _c (kN) | h _e (mm) | k _e | P _c (kN) | h _e (mm) | k _e |
| H = h | 2000 | 2.156 | 2000 | 1.000 | - | - | - |
| H = 2 h | 4000 | 0.776 | 3796 | 0.949 | 2.655 | 1736 | 0.434 |
| H = 2.667 h | 5333 | 0.535 | 4720 | 0.885 | 1.521 | 2512 | 0.471 |
| H = 3 h | 6000 | 0.380 | 5736 | 0.956 | 1.068 | 3132 | 0.522 |

b) SLBS with Mao Jue

| Distance between lateral restraints H (mm) | | Regular restraints | | | Staggered restraints | | |
|--|------|------------------------|------------------------|----------------|------------------------|------------------------|----------------|
| | | P _c (kN) | h _e (mm) | k _e | P _c (kN) | h _e (mm) | k _e |
| H = h | 2000 | 7.605 | 2000 | 1.000 | - | - | - |
| H = 2 h | 4000 | 2.405 | 3816 | 0.954 | 8.348 | 1892 | 0.473 |
| H = 2.667 h | 5333 | 1.545 | 4837 | 0.907 | 3.876 | 2938 | 0.551 |
| H = 3 h | 6000 | 1.135 | 5694 | 0.949 | 3.029 | 3366 | 0.561 |

c) DLBS with Mao Jue and Kao Jue

| Distance between lateral restraints H (mm) | | Regular restraints | | | Staggered restraints | | |
|--|------|------------------------|------------------------|----------------|------------------------|------------------------|----------------|
| | | P _c (kN) | h _e (mm) | k _e | P _c (kN) | h _e (mm) | k _e |
| H = h | 2000 | 2.156 | 2000 | 1.000 | - | - | - |
| H = 1.5 h | 3000 | 1.970 | 2124 | 1.062 | 2.313 | 1908 | 0.954 |
| H = 2 h | 4000 | 1.581 | 2451 | 1.226 | 2.285 | 1924 | 0.962 |
| H = 2.667 h | 5333 | 1.196 | 2921 | 1.460 | 1.929 | 2154 | 1.077 |
| H = 3 h | 6000 | 0.923 | 3424 | 1.712 | 1.766 | 2283 | 1.141 |

6. Design of bamboo scaffolds with worked examples

6.1 Introduction

This Chapter presents the general design principles of bamboo scaffolds. The design procedures of a number of typical structural bamboo members and scaffolding systems are fully presented through worked examples. Moreover, the design of both SLBS and DLBS are also fully presented with proper consideration of various arrangements of lateral restraints for practical applications.

6.2 General design principles

Bamboo scaffolds are tubular frameworks with high degree of structural redundancy. In typical bamboo scaffolds, most of the members such as the posts are under compression while some of them such as the base or the main ledgers are under bending. Overall stability of bamboo scaffolds are achieved through rational provision of vertical supports and lateral restraints.

In addition to primary structural members for direct load bearing, many secondary members such as standards, ledgers, and diagonals are also installed to share loads and to provide restraints to the primary members. The presence of all these secondary or bracing members ensures effective load distribution within the scaffolds, thus improving their structural performance significantly. Furthermore, in the event of local failure, effective load-redistribution within the scaffolds may readily be achieved without major adverse effect on the scaffolds.

As most of the ledgers are connected onto the posts with bamboo or plastic strips, all the connections may be considered to be pinned, i.e. the ledgers are allowed to rotate freely from the posts. However, due to the continuity of the ledgers over the post-ledger connections, the ledgers should be designed as continuous beams with simple supports, i.e. no moment is transferred to the posts. This situation is different from conventional structural design of both reinforced concrete and steel building structures.

In order to present simple design methods of bamboo scaffolds, it is recommended to firstly establish the minimum configuration of the scaffolds for overall stability and structural adequacy. This allows simple and clear identification of primary load paths within the scaffolds, and thus, the design of both compression and bending members may be readily achieved. Secondly, bracing members may then be introduced to provide secondary load paths within the scaffolds in order to enhance the structural behaviour of the scaffolds.

6.3 Standard dimensions of Kao Jue and Mao Jue

In structural design, the following dimensions of Kao Jue and Mao Jue may be adopted for general application:

- For Kao Jue, the external and the internal diameters are 40 and 30 mm respectively and they are considered to be constant along the length of the bamboo; the wall thickness is 5 mm.
- For Mao Jue, the external and the internal diameters at the top cross-section are 60 and 48 mm respectively and they are considered to increase linearly down to the bottom cross-section to 90 and 72 mm respectively over a length of 6 m. The wall thickness increases linearly from 6 mm at the top cross-section to 9 mm at the bottom cross-section.

These design data are considered to be conservative and should be adopted in the absence of measured and statistically corrected data.

6.4 Design of bamboo posts

Worked Example 1

The design of a bamboo post using a standard Kao Jue is presented where the height of the bamboo post is 2 m. The moisture content of Kao Jue under normal supply condition is taken as 12.5 %.

Worked Example 2

The design of a bamboo post using a standard Mao Jue is presented where the height of the bamboo post is 2 m. The moisture content of Mao Jue under normal supply condition is taken as 20 %.

6.5 Design of a bamboo transom and a bamboo ledger

Worked Example 3

The design of a simply supported bamboo transom using a standard Kao Jue under uniformly distributed load is presented in part a). The transom spans between the outer and the inner layers in a DLBS which are 0.6 m apart. The moisture content of Kao Jue under normal supply condition is taken as 12.5 %.

The design of a continuous bamboo ledger using a standard Kao Jue under single point load is presented in part b). The ledger spans between the posts of 2.1 m apart in a SLBS. The moisture content of Kao Jue under normal supply condition is taken as 12.5 %.

6.6 Design of a SLBS

Worked Example 4

The design of a short span SLBS is presented where standard Kao Jue is used as bamboo posts and ledgers. The horizontal spacing between the posts and the standards are 1.2 m while the vertical spacing between the ledgers are 2 m. Additional secondary ledgers of Kao Jue are also provided between the ledgers at a vertical spacing of 0.666 m. The moisture content of Kao Jue under normal supply condition is taken as 12.5 %. The design of a bamboo ledger using a standard Kao Jue is also presented.

Worked Example 5

The design of a long span SLBS is presented where standard Mao Jue is used as bamboo posts and the base ledger. The horizontal spacing between Mao Jue is 1.8 m while the vertical spacing between the ledgers is 2 m. The moisture content of Mao Jue under normal supply condition is taken as 20 %. Additional secondary ledgers of Kao Jue are also provided at a vertical spacing of 0.666 m. The design of a bamboo base ledger using a standard Mao Jue is also presented.

Through the use of effective length coefficients on bamboo posts as recommended in Section 5.6, the effects of various lateral restraint arrangements are incorporated in the design of SLBS.

6.7 Design of a DLBS

Worked Example 6

The design of a DLBS is presented with the following configuration:

- Mao Jue is used as the main posts of the outer layer where the posts are 2.1 m apart.
- Kao Jue is used as the main posts of the inner layer where the posts are 1.05 m apart.
- Mao Jue is also used as the base ledger of the outer layer.
- Kao Jue is used as the main ledgers of both the outer and the inner layers; the vertical spacing between the ledgers of both the outer and the inner layers are 2 m.
- Additional secondary ledgers of Kao Jue are also provided in the outer layers at a vertical spacing of 0.666 m.
- Mao Jue is also as the diagonals of the outer layer.

The moisture contents of Mao Jue and Kao Jue under normal supply condition are taken as 20% and 12.5% respectively.

The Worked Example presents the typical configuration of a DLBS commonly used in Hong Kong. Through the use of effective length coefficients on bamboo posts as recommended in Section 5.6, the effects of staggered lateral restraints on the load carrying capacities of the posts of both the inner and the outer layers are incorporated. The design procedure is fully presented in the following parts while the load path and hence the structural system of the DLBS is described in details:

- a) Design of a bamboo transom supporting a working platform
- b) Design of ledgers in the outer layer supporting the transom
- c) Design of the posts in both the inner and the outer layers
- d) Connection design
- e) Design of supports
- f) Column buckling design of Kao Jue as a post in the inner layer
- g) Column buckling design of Mao Jue as a post in the outer layer

Worked Example 1: Design of a bamboo post using Kao Jue

Design Data

| | | | |
|--------------------------------|------|------|-------------|
| <i>m.c.</i> (%) | 5 | 20 | 12.5 |
| E_b (kN/mm ²) | 22.0 | 16.4 | 19.2 |
| $p_{c,k}$ (N/mm ²) | 79 | 35 | 57 |

Member length $L = 2000$ mm
 Effective length factor $k_E = 1.00$
 Effective length $L_E = 2000$ mm

| | Cross section 1 | Cross section 2 |
|------------------------------|--|--|
| External diameter | $D_e = 40$ mm | $D_e = 40$ mm |
| Internal diameter | $D_i = 30$ mm | $D_i = 30$ mm |
| Cross-sectional area | $A_1 = \pi(D_e^2 - D_i^2) / 4$ $= 550$ mm ² | $A_2 = \pi(D_e^2 - D_i^2) / 4$ $= 550$ mm ² |
| Second moment of area | $I_1 = \pi(D_e^4 - D_i^4) / 64$ $= 85903$ mm ⁴ | $I_2 = \pi(D_e^4 - D_i^4) / 64$ $= 85903$ mm ⁴ |
| Radius of gyration | $r_{y1} = \text{SQRT}(I_1 / A_1)$ $= 12.50$ mm | |
| Slenderness ratio of section | $\lambda_1 = L_e / r_{y1}$ $= 160.00$ | |
| Ratio of section change | $\rho = (I_2 / I_1) - 1$ $= 0.000$ | |
| Non-prismatic parameter | $\alpha = 1.000$ | |

Young's Modulus against bending $E_b = 19.2$ kN/mm² $\gamma_m = 1.0$

Design compressive strength $p_c = 38$ N/mm² $\gamma_m = 1.5$

Elastic critical buckling strength $p_{cr} = \alpha (\pi^2 E_b / \lambda_1^2)$
 $= 7.40$ N/mm²

Column Buckling Curve

Robertson constant $a = 28$
 Limiting slenderness $\lambda_0 = \text{SQRT}(\pi^2 E_b / p_c)$
 $= 70.62$

Perry factor $\eta = 0.001 a (\lambda_1 - 0.2 \lambda_0)$
 $= 4.08$
 $\phi = [p_c + (1 + \eta) p_{cr}] / 2$
 $= 37.8$ N/mm²

Design compressive strength against column buckling $p_{c,c} = p_{cr} p_c / [\phi + (\phi^2 - p_{cr} p_c)^{1/2}]$
 $= 3.9$ N/mm²

Modified slenderness $\bar{\lambda} = \text{SQRT}(p_c / p_{c,c})$
 $= 2.27$

Modified strength $\bar{\psi}_c = p_{c,c} / p_c$
 $= 0.10$

Axial load resistance $P = p_{c,c} A_1$
 $= 2.156$ kN

Worked Example 2: Design of a bamboo post using Mao Jue

Design Data

| <i>m.c.</i> (%) | 5 | 30 | 20 |
|--------------------------------|------|-----|------|
| E_b (kN/mm ²) | 13.2 | 9.6 | 11.0 |
| $p_{c,k}$ (N/mm ²) | 117 | 44 | 73 |

Member length $L = 2000$ mm
 Effective length factor $k_E = 1.00$
 Effective length $L_E = 2000$ mm

| | Cross section 1 | Cross section 2 |
|-----------------------|---|---|
| External diameter | $D_e = 60$ mm | $D_e = 70$ mm |
| Internal diameter | $D_i = 48$ mm | $D_i = 56$ mm |
| Cross-sectional area | $A_1 = \pi(D_e^2 - D_i^2) / 4$ $= 1018$ mm ² | $A_2 = \pi(D_e^2 - D_i^2) / 4$ $= 1385$ mm ² |
| Second moment of area | $I_1 = \pi(D_e^4 - D_i^4) / 64$ $= 375596$ mm ⁴ | $I_2 = \pi(D_e^4 - D_i^4) / 64$ $= 695838$ mm ⁴ |

Radius of gyration $r_{y1} = \text{SQRT}(I_1 / A_1)$
 $= 19.21$ mm

Slenderness ratio of section $\lambda_1 = L_e / r_{y1}$
 $= 104.12$

Ratio of section change $\rho = (I_2 / I_1) - 1$
 $= 0.853$

Non-prismatic parameter $\alpha = -0.011 \rho^2 + 0.4751 \rho + 1.005$
 $= 1.402$

Young's Modulus against bending $E_b = 11.0$ kN/mm² $\gamma_m = 1.0$

Design compressive strength $p_c = 49$ N/mm² $\gamma_m = 1.5$

Elastic critical buckling strength $p_{cr} = \alpha (\pi^2 E_b / \lambda_1^2)$
 $= 14.09$ N/mm²

Column Buckling Curve

Robertson constant $a = 15$

Limiting slenderness $\lambda_0 = \text{SQRT}(\pi^2 E_b / p_c)$
 $= 47.25$

Perry factor $\eta = 0.001 a (\lambda_1 - 0.2 \lambda_0)$
 $= 1.42$

$\phi = [p_c + (1 + \eta) p_{cr}] / 2$
 $= 41.5$ N/mm²

Design compressive strength against column buckling $p_{c,c} = p_{cr} p_c / [\phi + (\phi^2 - p_{cr} p_c)^{1/2}]$
 $= 9.4$ N/mm²

Modified slenderness $\bar{\lambda} = \text{SQRT}(p_c / p_{cr})$
 $= 1.86$

Modified strength $\bar{\psi}_c = p_{c,c} / p_c$
 $= 0.19$

Axial load resistance $P = p_{c,c} A_1$
 $= 9.517$ kN

Note: If the Mao Jue is assumed to be prismatic with the external and the internal diameters at 60 and 48 mm respectively, the axial load resistance is 7.63 kN.

Worked Example 3: Design of a bamboo transom and a bamboo ledger using Kao Jue

| | | |
|--|-----------------------|------------------------------|
| Kao Jue section properties | $m.c. = 12.5 \%$ | $E_b = 19.2 \text{ kN/mm}^2$ |
| $D_e = 40 \text{ mm}$ | | $f_b = 39 \text{ N/mm}^2$ |
| $D_i = 30 \text{ mm}$ | | $f_c = 38 \text{ N/mm}^2$ |
| $A = 550 \text{ mm}^2$ | | |
| $I = 85903 \text{ mm}^4$ | | |
| $Z = 85903 / 20$ | $= 4295 \text{ mm}^3$ | |
| $M_K = 4295 \times 39 \times 10^{-6}$ | $= 0.17 \text{ kNm}$ | |
| $V_K = 0.25 \times 38 \times 550 \times 10^{-3}$ | $= 5.22 \text{ kN}$ | |

a) Design of a simply supported beam under uniformly distributed load - a bamboo transom

Design load

| | | | |
|----------------------------|---|----------|--|
| Construction load | = | 1.5 kPa | for 'light duty' scaffold |
| Self-weight allowance | = | 0.15 kPa | for self-weight of bamboo scaffold and timber plank. |
| Shear force coefficient | = | 0.5 | |
| Bending moment coefficient | = | 0.125 | |

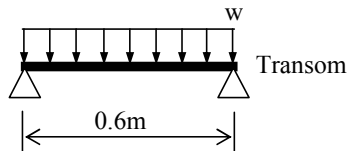

Design load on a working platform

$$w = (1.6 \times 1.5 + 1.4 \times 0.15) \times 1.05\text{m} = 2.74 \text{ kN/m (factored)}$$

Check against shear force

$$V_{\max} = 0.5 \times 2.74 \times 0.6 = 0.82 \text{ kN} < V_K = 5.22 \text{ kN}$$

(factored load to be supported by ledgers)

Check against bending moment

$$M_{\max} = 0.125 \times 2.74 \times 0.6^2 = 0.12 \text{ kNm} < M_K = 0.17 \text{ kNm}$$

The Kao Jue is structurally adequate to be used as a transom.

b) Design of a continuous beam under single point load - a bamboo ledger

| | | | |
|----------------------------|---|----------|--|
| Design load | = | 0.822 kN | from the working platform. |
| Shear force coefficient | = | 1.062 | for max shear force after considering load combination. |
| Bending moment coefficient | = | 0.213 | for max sagging moment or 0.188 for max hogging moment after considering load combination. |

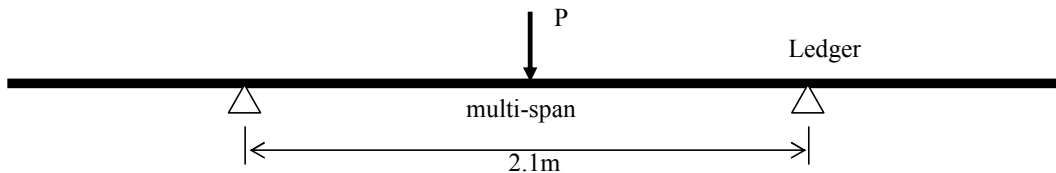

$$P = 0.82 \text{ kN}$$

Check against shear force

$$V_{\max} = 1.062 \times 0.82 = 0.87 \text{ kN} < V_K = 5.22 \text{ kN}$$

Check against bending moment

$$M_{\max} = 0.213 \times 0.82 \times 2.1 = 0.37 \text{ kNm} > M_K = 0.17 \text{ kNm}$$

Use three number of ledgers to resist the single point load.

$$3 \times M_K = 3 \times 0.17 = 0.50 \text{ kNm} > M_{\max} = 0.37 \text{ kNm}$$

Three numbers of Kao Jue are required to be used as ledgers to resist the single point load from the working platform.

Worked Example 4: Design of a short span Single Layered Bamboo Scaffold (SLBS) using Kao Jue

It is necessary to check the structural adequacy of the SLBS in providing access for workers.

The design load is the self-weight of a worker which is taken commonly as 80kg.

| | | | |
|--|-----------------------|------------------------------|--|
| Kao Jue section properties | $m.c. = 12.5 \%$ | $E_b = 19.2 \text{ kN/mm}^2$ | |
| $D_e = 40 \text{ mm}$ | | $f_b = 39 \text{ N/mm}^2$ | |
| $D_i = 30 \text{ mm}$ | | $f_c = 38 \text{ N/mm}^2$ | |
| $A = 550 \text{ mm}^2$ | | | |
| $I = 85903 \text{ mm}^4$ | | | |
| $Z = 85903 / 20$ | $= 4295 \text{ mm}^3$ | | |
| $M_k = 4295 \times 39 \times 10^{-6}$ | $= 0.17 \text{ kNm}$ | | |
| $V_k = 0.25 \times 38 \times 550 \times 10^{-3}$ | $= 5.22 \text{ kN}$ | | |

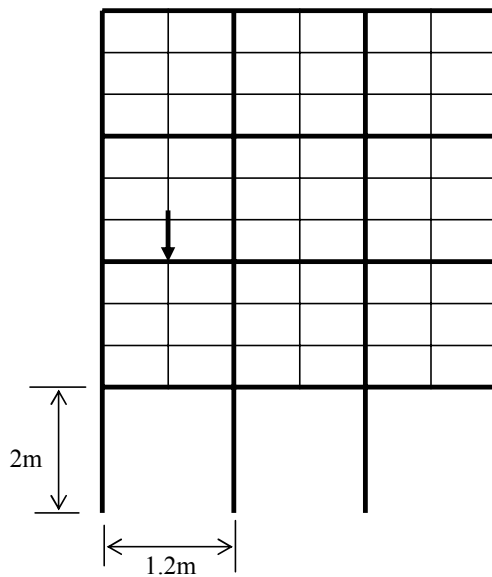

(Diagonals and bracing members not drawn for clarity)

Design load, F

$$F = 1.6 \times 80 \text{ kg} \times 9.81 / 1000 = 1.26 \text{ kN} \quad (\text{factored})$$

$$V_{\max} = 1.062 \times 1.26 = 1.33 \text{ kN} < V_k = 5.22 \text{ kN}$$

$$M_{\max} = 0.213 \times 1.26 \times 1.2 = 0.321 \text{ kNm} < 3 \times M_k = 3 \times 0.17 = 0.50 \text{ kNm}$$

Thus, three numbers of Kao Jue are required to support the self-weight of a worker.

From Worked Example 1, the axial load resistance of a Kao Jue with an effective length of 2 m is 2.16 kN.

In practice, various arrangement of lateral restraints should be considered as follows:

| Case | h = 2000 mm | Lateral restraints | P (kN) | Structural Adequacy |
|------|-------------|--------------------|--------|---------------------|
| a | H = h | regular | 2.156 | Y |
| b | H = 2 h | regular | 0.711 | N |
| c | H = 2 h | staggered | 1.280 | Y |
| d | H = 2.667 h | regular | 0.433 | N |
| e | H = 2.667 h | staggered | 0.798 | N |
| f | H = 3 h | regular | 0.351 | N |
| g | H = 3 h | staggered | 0.654 | N |

Only cases a and c are structurally adequate. In practice, case c is recommended, i.e. lateral restraints may be provided at a maximum distance of 4000 mm in a staggered manner.

Worked Example 5: Design of a long span Single Layered Bamboo Scaffold (SLBS) using Mao Jue

It is necessary to check the structural adequacy of the SLBS in providing access for workers. The design load is the self-weight of a worker which is taken commonly as 80kg.

| | | |
|---|------------------------|------------------------------|
| Mao Jue section properties | $m.c. = 20.0 \%$ | $E_b = 11.0 \text{ kN/mm}^2$ |
| $D_e = 60 \text{ mm}$ | | $f_b = 35 \text{ N/mm}^2$ |
| $D_i = 48 \text{ mm}$ | | $f_c = 49 \text{ N/mm}^2$ |
| $A = 1018 \text{ mm}^2$ | | |
| $I = 375596 \text{ mm}^4$ | | |
| $Z = 375596 / 30$ | $= 12520 \text{ mm}^3$ | |
| $M_M = 12520 \times 35 \times 10^{-6}$ | $= 0.44 \text{ kNm}$ | |
| $V_M = 0.25 \times 49 \times 1018 \times 10^{-3}$ | $= 12.47 \text{ kN}$ | |

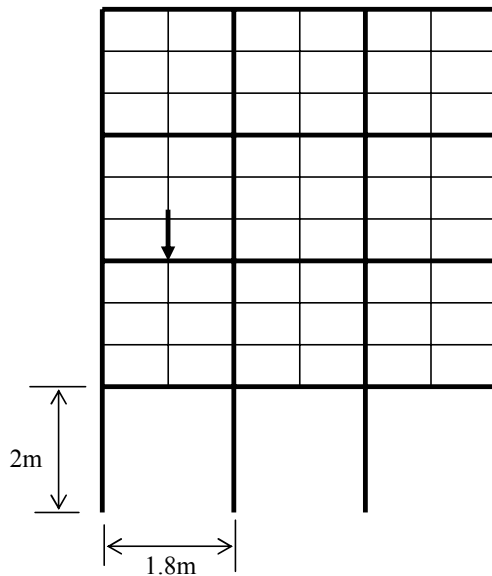

(Diagonals and bracing members not drawn for clarity)

Design load, F

$$F = 1.6 \times 80 \text{ kg} \times 9.81 / 1000 = 1.26 \text{ kN} \quad (\text{factored})$$

$$V_{\max} = 1.062 \times 1.26 = 1.33 \text{ kN} < V_M = 12.47 \text{ kN}$$

$$M_{\max} = 0.213 \times 1.26 \times 1.8 = 0.481 \text{ kNm} < M_M + M_K$$

$$= 0.44 + 0.17$$

$$= 0.61 \text{ kNm}$$

Thus, one Mao Jue and one Kao Jue are required to support the self-weight of a worker.

From Worked Example 2, the axial load resistance of a Mao Jue with an effective length of 2 m is 9.517 kN.

In practice, various arrangement of lateral restraints should be considered as follows:

| Case | $h = 2000 \text{ mm}$ | Lateral restraints | P (kN) | Structural adequacy for 2 workers | Structural adequacy for 3 workers |
|------|-----------------------|--------------------|--------|-----------------------------------|-----------------------------------|
| a | $H = h$ | regular | 9.517 | Y | Y |
| b | $H = 2 h$ | regular | 2.919 | Y | N |
| c | $H = 2 h$ | staggered | 5.468 | Y | Y |
| d | $H = 2.667 h$ | regular | 1.725 | N | N |
| e | $H = 2.667 h$ | staggered | 3.305 | Y | N |
| f | $H = 3 h$ | regular | 1.386 | N | N |
| g | $H = 3 h$ | staggered | 2.672 | Y | N |

For SLBS supporting 2 workers at any one time, cases e and g are structurally adequate. In practice, case e is recommended, i.e. lateral restraints may be provided at a maximum distance of 5333 mm in a staggered manner.

For SLBS supporting 3 workers at any one time, cases a and c are structurally adequate. In practice, case c is recommended, i.e. lateral restraints may be provided at a maximum distance of 4000 mm in a staggered manner.

Worked Example 6: Design of a Double Layered Bamboo Scaffold (DLBS)

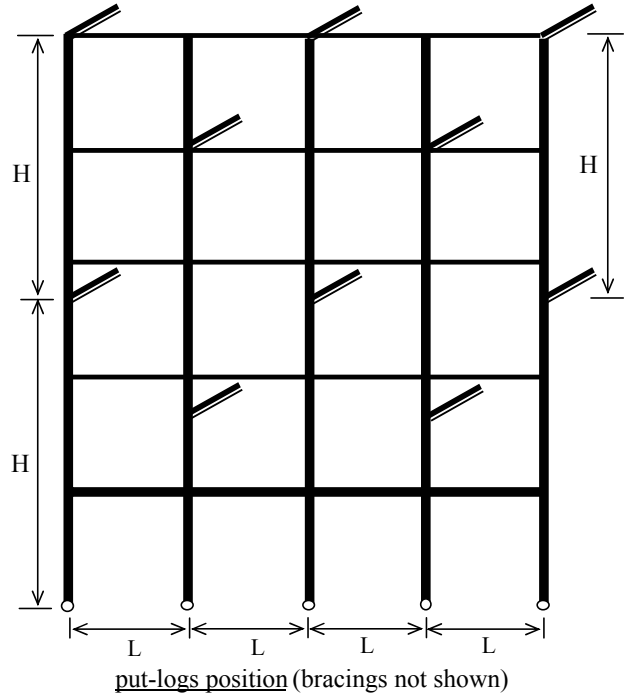
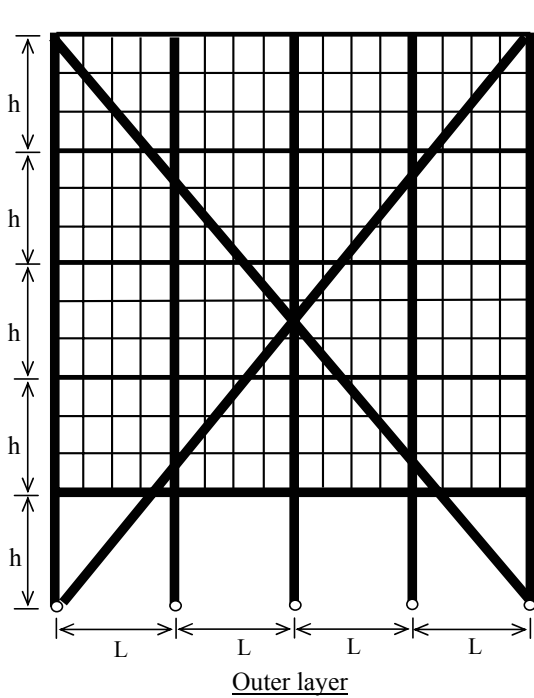

Transoms connected to posts of the outer layer
 Transoms connected to ledgers of the outer layer

L denotes post spacing
 h denotes height of a working platform
 H denotes distance between pull-logs
 WP denotes working platform
 Design load = 1.5 kPa per working platform

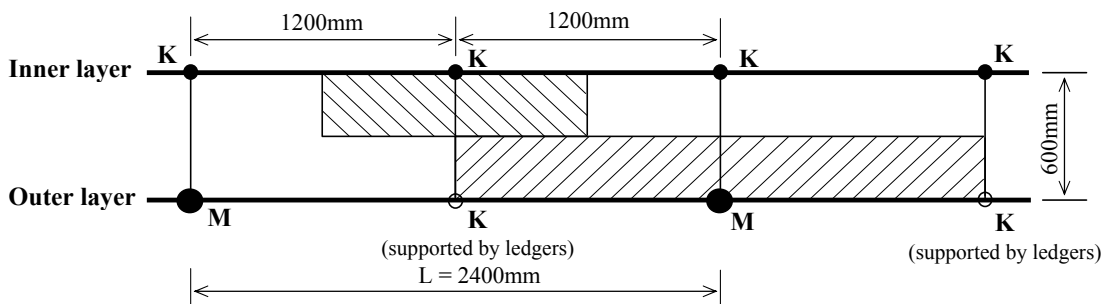
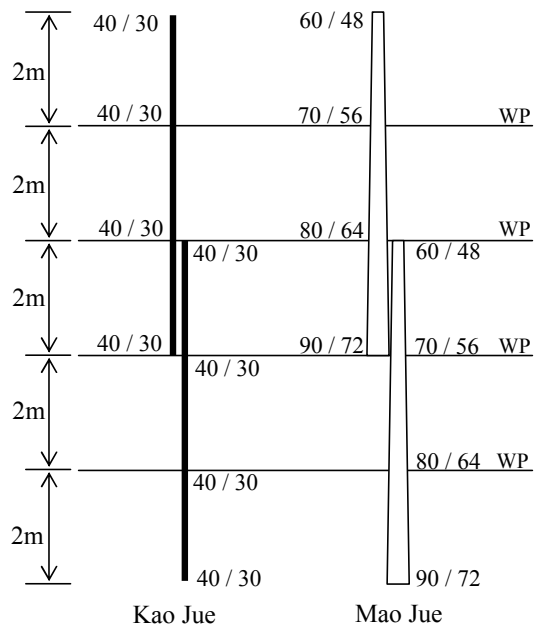
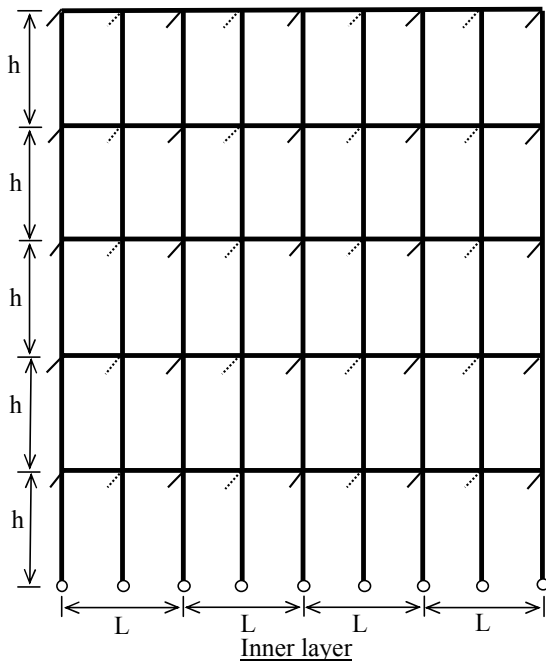

Section Properties

Kao Jue $m.c. = 12.5 \%$ $E_b = 19.2 \text{ kN/mm}^2$

$D_e = 40 \text{ mm}$ $f_b = 39 \text{ N/mm}^2$

$D_i = 30 \text{ mm}$ $f_c = 38 \text{ N/mm}^2$

$A = 550 \text{ mm}^2$

$I = 85903 \text{ mm}^4$

$Z = 85903 / 20 = 4295 \text{ mm}^3$

$M_K = 4295 \times 39 \times 10^{-6} = 0.168 \text{ kNm}$

$V_K = 0.25 \times 38 \times 550 \times 10^{-3} = 5.223 \text{ kN}$

Mao Jue $m.c. = 20.0 \%$ $E_b = 11.0 \text{ kN/mm}^2$

$D_e = 60 \text{ mm}$ $f_b = 35 \text{ N/mm}^2$

$D_i = 48 \text{ mm}$ $f_c = 49 \text{ N/mm}^2$

$A = 1018 \text{ mm}^2$

$I = 375596 \text{ mm}^4$

$Z = 375596 / 30 = 12520 \text{ mm}^3$

$M_M = 12520 \times 35 \times 10^{-6} = 0.438 \text{ kNm}$

$V_M = 0.25 \times 49 \times 1018 \times 10^{-3} = 12.469 \text{ kN}$

Design load

Construction load = 1.5 kPa for 'light duty' scaffold per platform

Self-weight = 0.15 kPa for self-weight of scaffold and timber plank per platform

a) Design of a bamboo transom supporting a working platform

Shear force coefficient = 0.5

Bending moment coefficient = 0.125

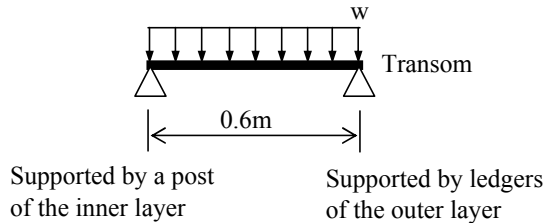

Design load on a working platform

$w = (1.6 \times 1.5 + 1.4 \times 0.15) \times 1.2\text{m} = 2.741 \text{ kN/m (factored)}$

Check against shear force

$V_{\max} = 0.5 \times 2.741 \times 0.6 = 0.822 \text{ kN} < V_K = 5.223 \text{ kN}$

Check against bending moment

$M_{\max} = 0.125 \times 2.741 \times 0.6^2 = 0.123 \text{ kNm} < M_K = 0.168 \text{ kNm}$

The Kao Jue is structurally adequate to be used as a transom.

The applied load acting on the working platform is transferred to the transom which is in turn supported by the ledgers of the outer layer and also by the post in the inner layer.

b) Design of ledgers in the outer layer supporting the transom

Design load = 0.822 kN from a transom
 Shear force coefficient = 1.062 after considering load combination.
 Bending moment coefficient = 0.213 max sagging moment or 0.188 max hogging moment after considering load combination.

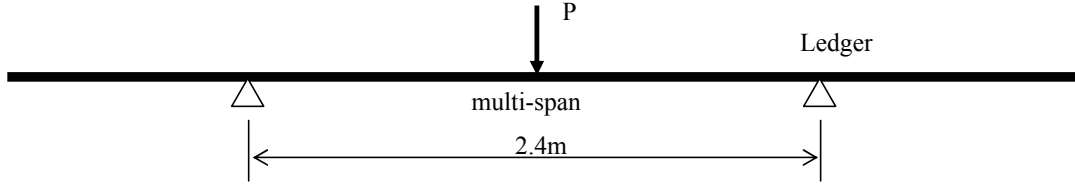

$$P = 0.822 \text{ kN}$$

Check against shear force

$$V_{\max} = 1.062 \times 0.822 = 0.873 \text{ kN} < V_K = 5.223 \text{ kN}$$

Check against bending moment

$$M_{\max} = 0.213 \times 0.822 \times 2.4 = 0.420 \text{ kNm}$$

Use three number of ledgers to resist the applied load.

$$M = 3 \times 0.168 = 0.503 \text{ kNm} > M_{\max} = 0.420 \text{ kNm}$$

For each working platform, three number of Kao Jue are required as ledgers in the outer layer to carry the applied load from the transom through a standard (a Kao Jue). Eventually, the applied load is transferred to the post (Mao Jue) of the outer layer.

c) Design of the posts in both the inner and the outer layer.

For each loaded working platform,

$$F_K = (1.6 \times 1.5 + 1.4 \times 0.15) \times 1.2 \times 0.3 = 0.822 \text{ kN in the inner layer}$$

$$F_M = (1.6 \times 1.5 + 1.4 \times 0.15) \times 2.4 \times 0.3 = 1.644 \text{ kN in the outer layer}$$

In the inner layer, Kao Jue is used as posts which are restrained laterally with transoms and put-logs with $H = 2.667 h$ in a staggered manner.

$$h_e = k_i \times k_b \times h$$

$$h_e = 1.5 \times 0.7 \times 2000 = 2100 \text{ mm}$$

$$P_K = 2.004 \text{ kN} \quad \text{Refer to part (f) below for detailed calculation.}$$

In the outer layer, Mao Jue is used as posts which are restrained laterally with pull-logs with $H = 2.667 h$ in a staggered manner.

$$h_e = k_o \times k_b \times H$$

$$h_e = 0.7 \times 0.7 \times 2.667 \times 2000 = 2613 \text{ mm}$$

$$P_M = 10.462 \text{ kN} \quad \text{Refer to part (g) below for detailed calculation.}$$

Number of loaded working platforms

$$\begin{aligned}
 &= P_K / F_K \quad \text{or} \quad P_M / F_M \\
 &= 2.004 / 0.822 \quad \text{or} \quad 10.462 / 1.644 \\
 &= 2.438 \quad \text{or} \quad 6.363 \\
 &= 2
 \end{aligned}$$

Hence, only two working platforms may be loaded at the same time, and the design is controlled by column buckling of Kao Jue in the inner layer.

Check the structural adequacy of DLBS

Inner layer: $P_K = 2.004 \text{ kN}$

$$\begin{aligned} \text{No. of loaded platforms} &= 2 \\ \text{Total factored load} &= 2 \times 0.822 = 1.644 \text{ kN} \\ \text{No. of unloaded platform} &= 2 \\ \text{Total factored load} &= 2 \times (1.4 \times 0.15 \times 1.2 \times 0.3) = 0.151 \text{ kN} \\ &\text{Total} = 1.796 \text{ kN} \\ &< P_K = 2.004 \text{ kN} \end{aligned}$$

Outer layer: $P_M = 10.462 \text{ kN}$

$$\begin{aligned} \text{No. of loaded platforms} &= 2 \\ \text{Total factored load} &= 2 \times 1.930 = 3.860 \text{ kN} \\ \text{No. of unloaded platform} &= 2 \\ \text{Total factored load} &= 2 \times (1.4 \times 0.15 \times 2.4 \times 0.3) = 0.302 \text{ kN} \\ &\text{Total} = 4.162 \text{ kN} \\ &< P_M = 10.462 \text{ kN} \end{aligned}$$

Consequently, the DLBS is structurally adequate to provide four working platforms but only two of them should be loaded at any one time subject to a maximum construction load of 1.5 kPa each.

d) Connection design

Transom-post connection

The maximum connection force in a DLBS is 1.644 kN which is the factored load from a loaded working platform through a transom to a post in the outer layer.

It should be noted that for each K-K, K-M and M-M fastening using either plastic strips or bamboo strips, the fastening resistance is 1.10 kN. Moreover, in each transom-post fastening, there is always a ledger-post fastening connected together, and thus, the total connection resistance is 2.20 kN, i.e. larger than the maximum connection force, 1.644 kN.

Column splices

The maximum force in the posts of a DLBS is 4.162 kN which is the total factored load from two loaded and two unloaded working platforms.

Use at least four fastenings in all column splices, and the connection resistance is 4.40 kN, i.e. larger than the maximum applied load, 4.162 kN.

e) Design of supports

In general, bamboo scaffolds are supported with direct bearing on ground. However, it may be necessary to support the bamboo scaffolds from the walls of existing building through steel brackets and linking beams as follows:

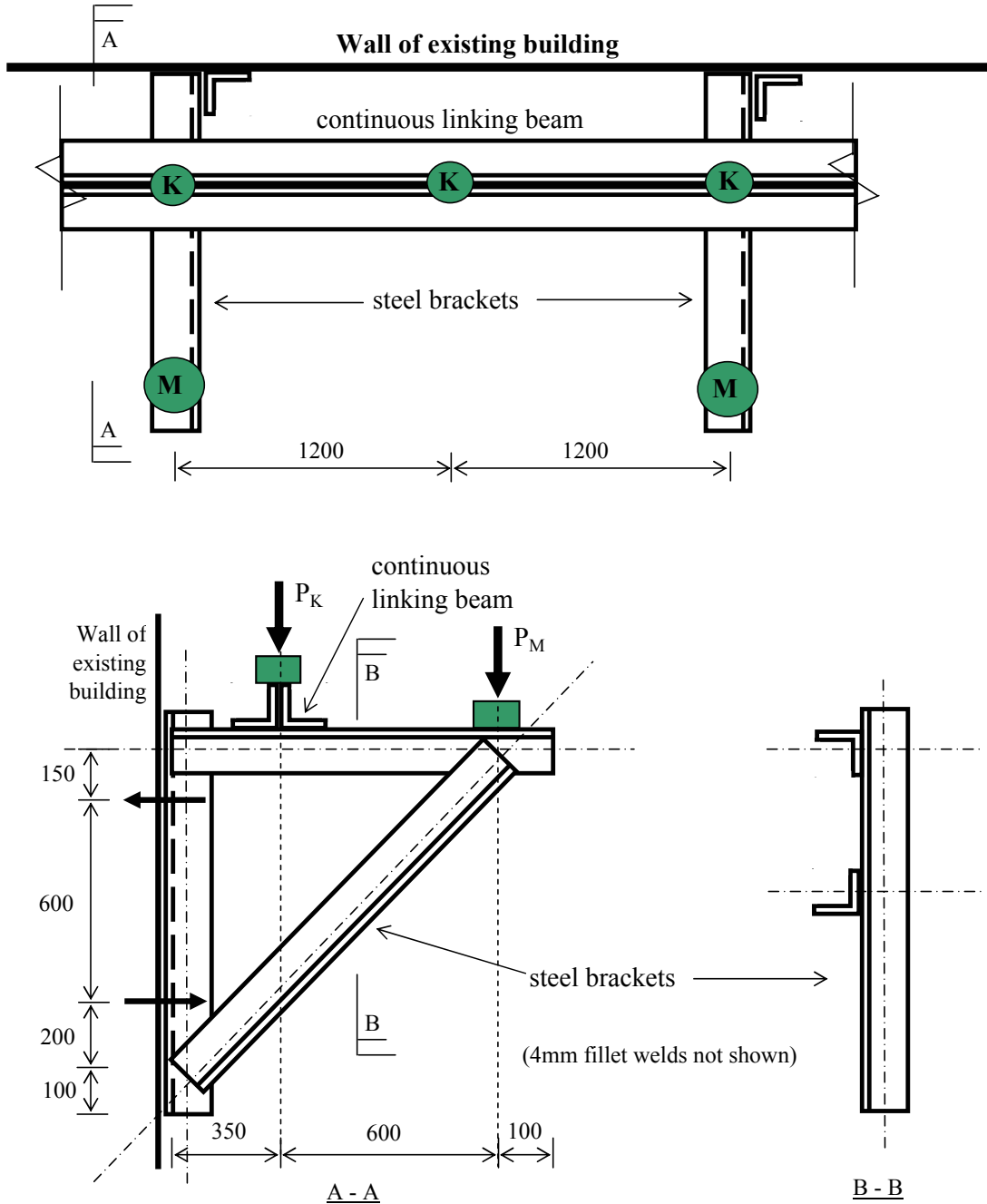

Loading:

- $P_K = 1.796 \text{ kN}$ (maximum load of Kao Jue in the inner layer)
- $P_M = 4.162 \text{ kN}$ (maximum load of Mao Jue in the outer layer)

For simplicity, use only one steel angle section for all members.

Check for the linking beam between two steel brackets

Use double angles (back to back) 50x50x5 Grade 43

$$Z_{xx} = 6.22 \times 10^3 \text{ mm}^3$$

$$I_{xx} = 22.2 \times 10^4 \text{ mm}^4$$

Bending moment coefficient = 0.213 for max sagging moment or 0.188 for max hogging moment after considering load combination.

$$L = 2400 \text{ mm}$$

$$M_{\max} = 0.213 \times 1.796 \times 2400 = 0.918 \text{ kNm}$$

$$Z_{\text{req}} = 0.918 \times 10^6 / 275 = 3.34 \times 10^3 \text{ mm}^3$$

$$< 6.22 \times 10^3 \text{ mm}^3 \quad \text{O.K.}$$

Deflection

$$\Delta = \frac{1}{48} \times \frac{1.796 \times 10^3 \times 2400^3}{205 \times 10^3 \times 22.2 \times 10^4}$$

$$= 11.366 \text{ mm}$$

$$= L / 211$$

$$< L / 180 \quad \text{O.K.}$$

Thus, double angles (back to back) 50x50x5 Grade 43 are structurally adequate to be used as a linking beam.

Check for the diagonal member of the steel bracket

$$P = 4.16 + 2 \times 1.796 \times \left(\frac{300}{300 + 600} \right) \\ = 5.359 \text{ kN}$$

$$\text{Maximum load acting on diagonal member} = 5.359 / \cos 45^\circ \\ = 7.579 \text{ kN}$$

$$L = (950^2 + 950^2)^{1/2} = 1343.5 \text{ mm}$$

Use single angle 50x50x5 Grade 43

$$A_g = 483 \text{ mm}^2$$

$$r_{vv} = 9.79 \text{ mm}$$

$$Z_{xx} = 3.11 \times 10^3 \text{ mm}^3$$

$$\lambda = 1343.5 / 9.79 = 137$$

$$p_c = 78 \text{ N/mm}^2 \quad (\text{BS5950:Part 1 Table 27c})$$

$$P_c = 78 \times 483 \times 10^{-3} = 37.67 \text{ kN}$$

$$> 7.579 \text{ kN} \quad \text{O.K.}$$

Check for anchor bolts

Use threaded mild steel bars of 10mm diameter

$$\begin{aligned} \text{Applied tension force, } F_t &= (2 \times 1.796 \times 300 + 4.162 \times 900) / 600 \\ &= 8.039 \text{ kN} \end{aligned}$$

$$\begin{aligned} \text{Applied shear force, } F_s &= 2 \times 1.796 + 4.162 \\ &= 7.754 \text{ kN} \end{aligned}$$

$$\begin{aligned} \text{Tension capacity, } p_t &= 275 \text{ N/mm}^2 && \text{(BS5950:Part 1 Table 32)} \\ A_t &= 78.5 \text{ mm}^2 \\ P_t &= 275 \times 78.5 \times 10^{-3} && = 21.59 \text{ kN} \\ &&& > 8.039 \text{ kN} \quad \mathbf{O.K.} \end{aligned}$$

$$\begin{aligned} \text{Shear capacity, } p_s &= 0.6 \times 275 && = 165 \text{ N/mm}^2 \\ A_s &= 78.5 \text{ mm}^2 \\ P_s &= 165 \times 78.5 \times 10^{-3} && = 12.95 \text{ kN} \\ &&& > 8.039 \text{ kN} \quad \mathbf{O.K.} \end{aligned}$$

Combined effect due to tension and shear forces

$$\begin{aligned} \frac{F_s}{P_s} + \frac{F_t}{P_t} &= \frac{7.754}{12.953} + \frac{8.039}{21.588} \\ &= 0.599 + 0.372 \\ &= 0.971 \\ &< 1.4 \quad \mathbf{O.K.} \end{aligned}$$

Sufficient anchorage to the mild steel bars should be provided.

g) Column buckling design of Mao Jue as a post in the outer layer

Design Data

| | | | |
|--------------------------------|------|-----|-------------|
| <i>m.c.</i> (%) | 5 | 30 | 20 |
| E_b (kN/mm ²) | 13.2 | 9.6 | 11.0 |
| $p_{c,k}$ (N/mm ²) | 117 | 44 | 73 |

| | | | |
|--|--|--------------------|--|
| Effective member length | $L_E = 2613$ | mm | |
| | Cross section 1 | | Cross section 2 |
| External diameter | $D_e = 70$ | mm | $D_e = 80$ mm |
| Internal diameter | $D_i = 56$ | mm | $D_i = 64$ mm |
| Cross-sectional area | $A_1 = \pi(D_e^2 - D_i^2) / 4$ $= 1385$ | mm ² | $A_2 = \pi(D_e^2 - D_i^2) / 4$ $= 1810$ mm ² |
| Second moment of area | $I_1 = \pi(D_e^4 - D_i^4) / 64$ $= 695838$ | mm ⁴ | $I_2 = \pi(D_e^4 - D_i^4) / 64$ $= 1187070$ mm ⁴ |
| Radius of gyration | $r_{y1} = \text{SQRT}(I_1 / A_1)$ $= 22.41$ | mm | |
| Slenderness ratio of section | $\lambda_1 = L_e / r_{y1}$ $= 116.59$ | | |
| Ratio of section change | $\rho = (I_2 / I_1) - 1$ $= 0.706$ | | |
| Non-prismatic parameter | $\alpha = -0.011 \rho^2 + 0.4751 \rho + 1.005$ $= 1.335$ | | |
| <i>Young's Modulus against bending</i> | $E_b = 11.0$ | kN/mm ² | $\gamma_m = 1.0$ |
| <i>Design compressive strength</i> | $p_c = 49$ | N/mm ² | $\gamma_m = 1.5$ |
| <i>Elastic critical buckling strength</i> | $p_{cr} = \alpha (\pi^2 E_b / \lambda_1^2)$ $= 10.70$ | N/mm ² | |
| Column Buckling Curve | | | |
| Robertson constant | $a = 15$ | | |
| Limiting slenderness | $\lambda_0 = \text{SQRT}(\pi^2 E_b / p_c)$ $= 47.25$ | | |
| Perry factor | $\eta = 0.001 a (\lambda_1 - 0.2 \lambda_0)$ $= 1.61$ | | |
| | $\phi = [p_c + (1 + \eta) p_{cr}] / 2$ $= 38.3$ | N/mm ² | |
| <i>Design compressive strength against column buckling</i> | $p_{c,c} = p_{cr} p_c / [\phi + (\phi^2 - p_{cr} p_c)^{1/2}]$ $= 7.6$ | N/mm ² | |
| Modified slenderness | $\bar{\lambda} = \text{SQRT}(p_c / p_{cr})$ $= 2.14$ | | |
| Modified strength | $\bar{\psi}_c = p_{c,c} / p_c$ $= 0.15$ | | |
| Axial load resistance | $P = p_{c,c} A_1$ $= 10.462$ | kN | |

Appendix A

Appendix A.1 Mechanical properties of various bamboo species - compression

Appendix A.2 Mechanical properties of various bamboo species - bending

Appendix A.3 Mechanical properties of various bamboo species – shear

For details of the data, refer to the following document:

Chan SL and Xian XJ (2001). Engineering and mechanical properties of structural bamboo. Technical Report, Research Centre for Advanced Technology in Structural Engineering, the Hong Kong Polytechnic University.

Appendix A.1 Mechanical properties of various bamboo species - compression

| Bamboo species | Author(s) | No. of tests | L (mm) | D (mm) | t (mm) | m.c. (%) | p_c (N/mm ²) | E_c (kN/mm ²) |
|--|------------|--------------|--------------|--------|---------|----------|----------------------------|-----------------------------|
| <i>Bambusa Spinosa</i> , China | Espinosa | 53 | 356 | 61 | - | - | 57 | - |
| <i>Bambusa Tuldooides</i> | Mc Clure | 21 | 305 | 47 | - | - | 35 | - |
| <i>Phyllostachys Bambusoides</i> | Glenn | 11 | 153 | | | | 51 | |
| <i>Denderocalamus Strictus</i> , India | Limaye | 33 | 152 | 36 | - | 64 | 44 | |
| | | 33 | 152 | 36 | | 61 | 40 | |
| | | 33 | 152 | 36 | | 9 | 71 | |
| | | 33 | 152 | 36 | | 9 | 74 | |
| <i>Bambusa Nutans</i> | Sekhar | 24 | | | | 87 | 46 | |
| | | 24 | | | | 12 | 85 | |
| <i>Denderocalamus Strictus</i> , India | Sekhar | 16 | 152 | 36 | | 12 | 54 | |
| <i>Phyllostachys Pubescens</i> , China | Yuen | | 75, 150 | 73.5 | | | 44.6 | 11.3 |
| <i>Bambusa Pevaribillis</i> , China | Yuen | | 75, 150 | 38.5 | | | 45.8 | 15.2 |
| <i>Bambusa Blumeana</i> , Philippine | Janssen | | 50, 100, 200 | 70-90 | 5-9 | 12 | 78 | 18.8 |
| | | 8 | | | | 80 | 18.8 | |
| | | 4 | | | | 83 | 18.8 | |
| <i>Phyllostachys Pubescens</i> , Japan | Ota | | | | | 50-99 | 67 | |
| | | | | | | 14-17 | 71 | |
| | | | | | | 5-7 | 108 | |
| | | | | | | 0.3-0.1 | 147 | |
| <i>Phyllostachys edulis</i> , Japan | Ota | | | | | 50-99 | 64 | |
| | | | | | | 14-17 | 76 | |
| | | | | | | 5-7 | 109 | |
| | | | | | | 0.3-0.1 | 140 | |
| <i>Phyllostachys ret.</i> , Japan | Ota | | | | 11-14 | 18.8-20 | 64-79 | |
| | | | | | 8.2-9.1 | 17.2-19 | 76-87 | |
| <i>Guadas.s.p.</i> , Costa Rica | Sotela | | | | | 15 | 42 | 27 |
| <i>Bambusa Pevaribillis</i> , China | Yu & Chung | 103 | 2D | 40.7 | 5.2 | <5 | 79 | 10.3 |
| | | 136 | | | | 5-20 | 48 | 9.3 |
| | | 125 | | | | >20 | 35 | 6.8 |
| <i>Phyllostachys Pubescens</i> , China | Yu & Chung | 9 | 2D | 68.6 | 7.1 | <5 | 117 | 9.4 |
| | | 41 | | | | 5-30 | 46 | 7.8 |
| | | 163 | | | | >30 | 44 | 6.4 |

Notes:

L denotes length of specimen

D denotes external diameter of specimen

t denotes thickness of specimen

m.c. denotes moisture content

p_c denotes typical compressive strength

E_c denotes typical Young's modulus against compression

Appendix A.2 Mechanical properties of various bamboo species - bending

| Bamboo species | Author(s) | No. of tests | Age (year) | L (mm) | D (mm) | t (mm) | m.c. (%) | p_b (N/mm ²) | E_b (kN/mm ²) |
|--|------------|--------------|------------|--------|--------|--------|----------|----------------------------|-----------------------------|
| <i>Bambusa Spinosa</i> , Philippine | Teodoro | | | 3000 | | | Dry | 55 | 10.3 |
| <i>Bambusa Vulgaris</i> , Philippine | Teodoro | | | 3000 | | | Dry | 33 | 18.4 |
| <i>Bambusa Spinosa R.</i> | Espinosa | 43 | | 300 | | | Dry | 143 | |
| | | 43 | | 300 | | | Dry | 113 | |
| <i>Phyllostachys</i> | Glenn | 19 | | - | | | - | 146 | 14.8 |
| | | 15 | | - | | | - | 143 | 14.3 |
| <i>Denderocalamus Strictus</i> , India | Limaye | 240 | | 700 | | | Green | 68 | 12 |
| | | 240 | | 700 | | | Dry | 107 | 15.6 |
| <i>Denderocalamus Strictus</i> | Limaye | 14 | 1 | 700 | | | 12 | 96 | 16 |
| | | 16 | 2 | 700 | | | 12 | 96 | 15.3 |
| | | 16 | 3 | 700 | | | 12 | 92 | 15.2 |
| | | 15 | 4 | 700 | | | 12 | 95 | 14.5 |
| | | 17 | 5 | 700 | | | 12 | 94 | 14.2 |
| | | 17 | 6 | 700 | | | 12 | 97 | 13.7 |
| <i>Bambusa Nutans</i> | Sekhar | 24 | 1 | 700 | | | Dry | 96 | 13.9 |
| | | 24 | 2 | 700 | | | Dry | 83 | 9.3 |
| | | 21 | 3 | 700 | | | Dry | 92 | 13.1 |
| | | 21 | 4 | 700 | | | Dry | 76 | 11 |
| | | 23 | 5 | 700 | | | Dry | 100 | 15.4 |
| | | 24 | 1 | 700 | | | Green | 61 | 9.4 |
| | | 24 | 2 | 700 | | | Green | 56 | 8.8 |
| | | 21 | 3 | 700 | | | Green | 59 | 9.4 |
| | | 21 | 4 | 700 | | | Green | 67 | 10.8 |
| | | 23 | 5 | 700 | | | Green | 79 | 13 |
| <i>Bambusa Spinosa</i> , Philippine | Espinosa | | | 1500 | 89.1 | 5.6 | Air dry | 71, 59.5 | |
| | | | | 1500 | 95.5 | 6.7 | Air dry | 62.4, 69.5 | |
| | | | | 1500 | 105 | 9 | Air dry | 55.4 | |
| | | | | 1500 | 111.4 | 9 | Air dry | 44.9 | |
| <i>Common philippine bamboo</i> | Espinosa | | | 700 | 67-80 | 5 | Air dry | 43-62 | |
| <i>Denderocalamus Strictus</i> , India | Limaye | | | 700 | | | 61 | 105 | 13.2 |
| | | | | 700 | | | 55 | 98.5 | 136 |
| <i>Guadva Angustifolia</i> , Costa Rica | Gnanaharan | | | 700 | | | | 53.5 | 7.4 |
| <i>Bambusa Pevaribillis</i> , China | Yu & Chung | 21 | 3 | 1000 | 40.7 | 5.2 | <5 | 80 | 22 |
| | | 53 | 3 | 1000 | | | 5-20 | 54 | 18.5 |
| | | 17 | 3 | 1000 | | | >20 | 37 | 16.4 |
| <i>Phyllostachys Pubescens</i> , China | Yu & Chung | 15 | 3 | 1000 | 68.6 | 7.1 | <5 | 51 | 13.2 |
| | | 32 | 3 | 1000 | | | 5-30 | 56 | 11.4 |
| | | 81 | 3 | 1000 | | | >30 | 55 | 9.6 |

Notes:

L denotes length of specimen

D denotes external diameter of specimen

t denotes thickness of specimen

m.c. denotes moisture content

p_b denotes typical bending strength

E_b denotes typical Young's modulus against bending

Appendix A.3 Mechanical properties of various bamboo species - shear

| Bamboo species | Author(s) | No. of tests | Age (year) | H (mm) | W (mm) | m.c. (%) | τ (N/mm ²) |
|--|-----------|--------------|------------|--------|--------|----------|-----------------------------|
| <i>Phyllostachys Pubescens</i> Mazel | Ota | 3 | | | | 12.5 | 8.9 |
| | | 5 | | 20 | 20 | | 12.5 |
| | | 5 | | 40 | 30 | | 10.5 |
| <i>Phyllostachys reticulata</i> C.Koch | Ota | 5 | | 40 | 30 | | 14.9 |
| | | 5 | | 40 | 30 | | 11.7 |
| <i>Bambusa Nutans</i> | Sekhar | 24 | 1 | 25 | 12 | | 6.7 |
| | | 36 | 2 | 37 | 25 | | 7.7 |
| | | 36 | 3 | 50 | 37 | | 7.9 |
| | | 33 | 4 | | 50 | | 9.8 |
| | | 48 | 5 | | | | 7.9 |
| <i>Phyllostachys Pubescens</i> , China | Dickerson | | | | | Green | 8.9 |
| <i>Bambusa Pevaribillis</i> , Philippine | Janssen | | 3 | | | 12 | 10.3 |
| | | | 3 | | | 12 | 8.7 |
| <i>Phyllostachys edulis</i> , Japan | Ota | | | | | 14.1 | 16.7 |
| | | | | | | 16.6 | 12.6 |
| <i>Phyllostachys reticulata</i> , Japan | Ota | | | 20 | 20 | 15.2 | 12.5 |
| | | | | 40 | 30 | | 10.5 |
| | | | | 20 | 20 | 14.6 | 14.9 |
| | | | | 40 | 20 | | 11.7 |

Notes:

H denotes height of specimen

W denotes width of specimen

m.c. denotes moisture content

τ denotes shear strength

References

1. American Forest and Paper Association (1995). ANSI / NfoPA NDS-1991 National Design Specification for Wood construction and Supplement, revised 1991 edition.
2. British Standards Institution (1995). BS EN 384: Structural timber. Determination of characteristic values of mechanical properties and density.
3. British Standards Institution (1996). BS5268: Structural use of timber. Part 2: Code of practice for permissible stress design, materials and workmanship.
4. British Standards Institution (1995). DD ENV 1995-1-1 Eurocode 5: Design of timber structures. Part 1.1 General rules and rules for buildings.
5. Fu WY (1993). Bamboo scaffolding in Hong Kong. *The Structural Engineer*, 71, 11, 202-204.
6. Hong Kong Construction Association (1995). Practice Guide for Bamboo Scaffolding Safety Management. Labour and Safety Committee.
7. So YS and Wong KW (1998). Bamboo scaffolding development in Hong Kong – A critical review. Proceedings of the Symposium on ‘Bamboo and Metal Scaffolding’, the Hong Kong Institution of Engineers, October 1998, 63-75.
8. Wong KW (1998). Bamboo scaffolding – Safety Management for the Building Industry in Hong Kong. Research Report, Department of Building and Real Estate, the Hong Kong Polytechnic University.
9. Au F, Ginsburg KM, Poon YM and Shin FG (1978). Report on study of bamboo as a construction material. The Hong Kong Polytechnic.
10. Janssen JJA (1981). Bamboo in building structures. Ph.D. thesis, Eindhoven University of Technology, Holland.
11. Janssen JJA (1991). Mechanical properties of bamboo. Kluwer Academic Publisher.
12. Amada S, Munekata T, Nagase Y, Ichikawa Y, Kirigai A and Yang Z (1997). The mechanical structures of bamboos in viewpoint of functionally gradient and composite materials. *Journal of Composite Materials*, 30, 7, 800-819.
13. Arce-Villalobos OA (1993). Fundamentals of the design of bamboo structures. Ph.D. thesis, Eindhoven University of Technology, Holland.
14. Gutierrez JA (1999). Structural adequacy of traditional bamboo housing in Latin-America. Technical Report No. 321-98-519, Laboratorio Nacional de Materiales y Modelos Estructurales, Universidad de Costa Rica, Costa Rica.
15. International Network for Bamboo and Rattan (1999). Buildings with bamboo arch roof at Harita Ecological Institute - A review report and recommendations for design upgradation. Technical Report. Society for Advancement of Renewable Materials and Energy Technologies.

16. Chan SL and Zhou ZH (1994). Second-order analysis of frames using a single imperfect element per member. *Journal of Structural Engineering*, ASCE, 120, 6, 703-717.
17. Chan SL, Wong KW, So YS and Poon SW (1998). Empirical design and structural performance of bamboo scaffolding. *Proceedings of the Symposium on Bamboo and Metal Scaffoldings*, the Hong Kong Institution of Engineers, May 1998, 5-21.
18. Chung KF, Chan SL and Yu WK (2002). Recent developments on bamboo scaffolding in building construction. *Proceedings of the International Conference on Advances in Building Technology*, Hong Kong, December 2002, 629-636.
19. Chung KF and Siu YC (2002). *Erection of Bamboo Scaffolds*. Technical Report No. 24, Jointly published by the International Network for Bamboo and Rattan and the Hong Kong Polytechnic University.
20. Chung KF, Yu WK and Ying K (2001). *Connections in Bamboo Scaffolds*. Technical Report, Research Centre for Advanced Technology in Structural Engineering, the Hong Kong Polytechnic University.
21. Chan SL and Xian XJ (2001). *Engineering and mechanical properties of structural bamboo*. Technical Report, Research Centre for Advanced Technology in Structural Engineering, the Hong Kong Polytechnic University.
22. Chung KF and Yu WK (2002). Mechanical properties of structural bamboo for bamboo scaffoldings. *Engineering Structures*, 24, 429-442.
23. Yu WK and Chung KF (2000). *Qualification tests on Kao Jue under compression and bending*. Technical Report, Research Centre for Advanced Technology in Structural Engineering, the Hong Kong Polytechnic University.
24. Yu WK and Chung KF (2000). *Qualification tests on Mao Jue under compression and bending*. Technical Report, Research Centre for Advanced Technology in Structural Engineering, the Hong Kong Polytechnic University.
25. Yu WK, Chung KF and Chan SL. *Column buckling of structural bamboo*. *Engineering Structures* (in press).
26. Chung KF, Yu WK and Chan SL. *Structural Stability of Bamboo Scaffolds*. *Engineering Structures* (in press).
27. Chung KF and Yu WK (2001). *Full scale tests of Double Layered Bamboo Scaffolds (DLBS)*. Technical Report, Research Centre for Advanced Technology in Structural Engineering, the Hong Kong Polytechnic University.
28. Chung KF and Yu WK (2001). *Full scale tests of Double Layered Bamboo Scaffolds with Kao Jue only (DLBS-KK)*. Technical Report, Research Centre for Advanced Technology in Structural Engineering, the Hong Kong Polytechnic University.
29. British Standards Institution (1997). *BS8110 Structural use of concrete. Part 1: Code of practice for design and construction*.

30. British Standards Institution (2000). BS5950 Structural use of steelwork in building. Part 1: Code of practice for design – Rolled and welded sections.
31. Janssen JJA (2001). An international model building code for bamboo. The International Network for Bamboo and Rattan.
32. Janssen JJA (2001). INBAR standard for determination of physical and mechanical properties of bamboo. The International Network for Bamboo and Rattan.
33. British Standards Institution (1993). BS5973: Code of practice for assess and working scaffolds and special scaffold structures in steel.



Bamboo scaffolds have been widely used in construction applications in South East Asia, in particular, Hong Kong for many years. Because of their high adaptability and low construction cost, bamboo scaffolds can be constructed in different shapes to follow any irregular architectural features of a building within a comparatively short period of time. In general, bamboo scaffolds are mainly used to provide access of workers to different exposed locations to facilitate various construction and maintenance process. Besides widely erected on construction sites, bamboo scaffolds are also used in signage erection, decoration work, demolition work and civil work.

This document *Design of Bamboo Scaffolds* presents the basic structural principles and the design method of bamboo scaffolds together with worked examples on typical use of bamboo scaffolds in building construction. It covers material requirements, typical applications, structural principles and safety requirements for structural engineers.

